

## LPC4357 Developer's Kit User's Guide

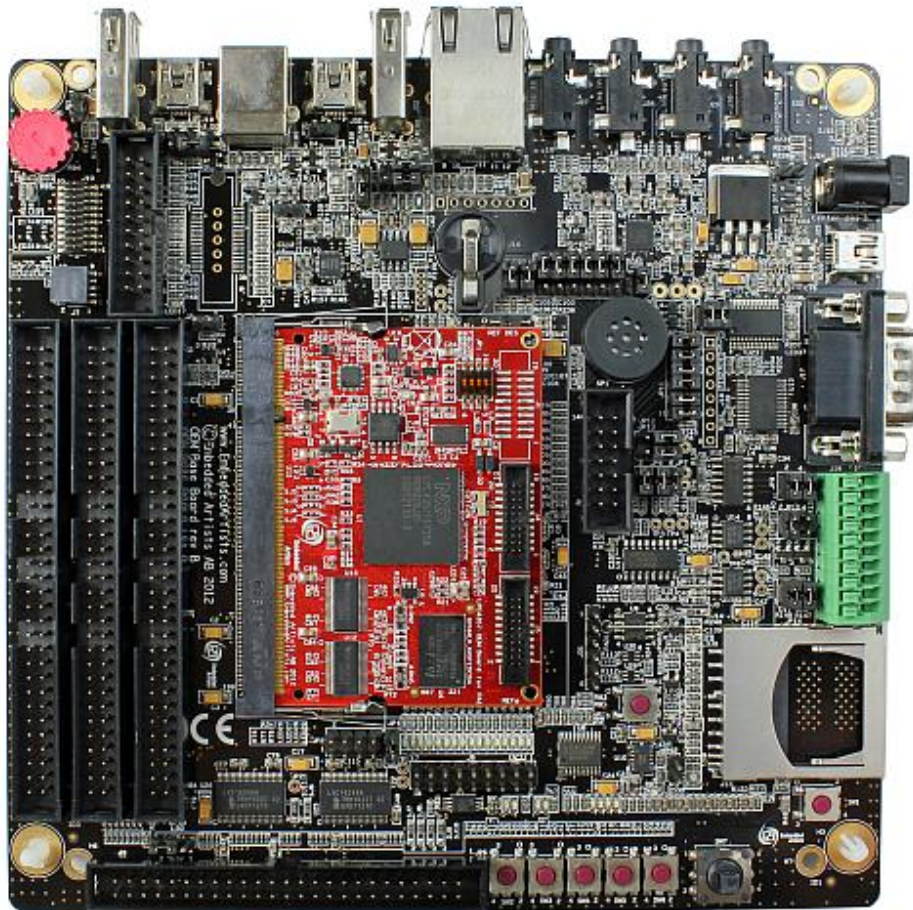

*Get Up-and-Running Quickly and  
Start Developing Your Application On Day 1!*

## Embedded Artists AB

Jörgen Ankersgatan 12  
211 45 Malmö  
Sweden

<http://www.EmbeddedArtists.com>

### **Copyright 2018 © Embedded Artists AB. All rights reserved.**

No part of this publication may be reproduced, transmitted, transcribed, stored in a retrieval system, or translated into any language or computer language, in any form or by any means, electronic, mechanical, magnetic, optical, chemical, manual or otherwise, without the prior written permission of Embedded Artists AB.

### **Disclaimer**

Embedded Artists AB makes no representation or warranties with respect to the contents hereof and specifically disclaim any implied warranties or merchantability or fitness for any particular purpose. Information in this publication is subject to change without notice and does not represent a commitment on the part of Embedded Artists AB.

### **Feedback**

We appreciate any feedback you may have for improvements on this document. Please send your comments to [support@EmbeddedArtists.com](mailto:support@EmbeddedArtists.com).

### **Trademarks**

All brand and product names mentioned herein are trademarks, services marks, registered trademarks, or registered service marks of their respective owners and should be treated as such.

# Table of Contents

<b>1</b>	<b>Document Revision History</b>	<b>5</b>
<b>2</b>	<b>Introduction</b>	<b>6</b>
2.1	Features	6
2.2	ESD Precaution	7
2.2.1	ESD sensitivity on JTAG interface	8
2.3	General Handling Care	8
2.4	Code Read Protection	8
2.5	CE Assessment	8
2.6	Other Products from Embedded Artists	9
2.6.1	Design and Production Services	9
2.6.2	OEM / Education / QuickStart Boards and Kits	9
<b>3</b>	<b>LPC4357 OEM Board Design</b>	<b>10</b>
3.1	Memory Layout	10
3.1.1	NAND Flash	10
3.2	SPIFI	11
3.3	Bootloader Mode Setting	11
3.4	Trace Connector	12
3.5	I2S and SGPIO Connectors	12
3.6	uSD Memory Card Interface	12
3.7	Board Options	13
3.8	1 kBit I2C E2PROM with EUI-48™ Number	13
<b>4</b>	<b>OEM Base Board Design</b>	<b>14</b>
4.1	Modifications to OEM Base Board	14
4.2	SP2: OEM Board Connector	15
4.3	SP2: Current Measurements	15
4.4	SP3: Expansion Connectors	15
4.5	SP4: External Memory Bus	16
4.6	SP5: Debug Interfaces	17
4.7	SP6: Ethernet Interface	19
4.8	SP6: SD/MMC Memory Card Interface	20
4.9	SP6: VBAT/ALARM Handling	21
4.10	SP7: I2C Peripherals	22
4.11	SP8: Analog Input	23
4.12	SP8: Digital IO	24
4.13	SP8: Serial Expansion Connector	24
4.14	SP8: NXP/Jennic RF Module Interface	26
4.15	SP9: UART Multiplexing	27
4.16	SP9: RS232 Interface	28

4.17	<b>SP9: RS422/485 Interface</b>	<b>29</b>
4.18	<b>SP10: CAN</b>	<b>30</b>
4.19	<b>SP10: IrDA</b>	<b>31</b>
4.20	<b>SP11: USB Channel 1</b>	<b>32</b>
4.20.1	USB Channel 1 as USB Host	33
4.20.2	USB Channel 1 as USB Device	33
4.20.3	USB Channel 1 as USB OTG	33
4.21	<b>SP12: USB Channel 2</b>	<b>34</b>
4.21.1	USB Channel 2 (USB0 on LPC4357) as USB Host	35
4.21.2	USB Channel 2 (USB0 on LPC4357) as USB Device	35
4.21.3	USB Channel 2 (USB0 on LPC4357) as USB OTG	35
4.22	<b>SP13: UART-to-USB Bridge</b>	<b>36</b>
4.23	<b>SP13: Power Supply</b>	<b>37</b>
4.24	<b>SP14: LCD Expansion Interface</b>	<b>37</b>
4.25	<b>SP15: I2S Audio Codec</b>	<b>38</b>
4.26	<b>Default Jumpers Positions</b>	<b>40</b>
4.27	<b>Usage of CPU Pins</b>	<b>41</b>
<b>5</b>	<b>Getting Started</b>	<b>47</b>
5.1	<b>Powering</b>	<b>47</b>
5.2	<b>Demo Application</b>	<b>47</b>
5.3	<b>Installing USB Driver</b>	<b>49</b>
5.4	<b>Program Download</b>	<b>49</b>
5.4.1	ISP over USB Program Download	50
5.5	<b>Handling SO-DIMM Boards</b>	<b>53</b>
5.6	<b>Things to Note</b>	<b>53</b>
5.6.1	Low Speaker Audio Volume	53
5.6.2	Humming in Speaker	54
5.6.3	Current Consumption and Limits of USB Ports	55
5.6.4	LCD flickering	55
5.6.5	Initialization of External Memory Bus	56
5.6.6	USB OTG Transceiver	56
5.6.7	External SDRAM Clock Frequency and CLK2_OUT	56
5.6.8	JTAG/SWD Connection Problems	56
5.6.9	I2C-address of E2PROM with EUI-48™ Number	56
<b>6</b>	<b>LCD Expansion Connector</b>	<b>57</b>
<b>7</b>	<b>Troubleshooting</b>	<b>60</b>
7.1	<b>No SWD/JTAG Connection</b>	<b>60</b>
7.2	<b>Powering</b>	<b>60</b>
7.3	<b>Contact with OEM Board MCU</b>	<b>61</b>
7.4	<b>Using Test Program to Verify Correct Operation</b>	<b>61</b>
<b>8</b>	<b>Further Information</b>	<b>62</b>

# 1 Document Revision History

<i>Revision</i>	<i>Date</i>	<i>Description</i>
PA1	2012-10-29	First version.
PA2	2012-12-08	Added information about ESD sensitive JTAG interface.
PA3	2013-01-21	Minor clarifications.
PA4	2013-04-08	Clarified that JP4 must be shorted (jumper installed) in order for the LPC4357 SWD/JTAG interface to function.
PA5	2013-06-04	Added information about external SDRAM frequency and CLK2_OUT signal relation, see section 5.6.7
PA6	2013-07-26	Updated section 5.4.1 for DFUsec ver 1.10.
PA7	2014-05-22	Corrected jumper description and DFUsec ver 1.11 in section 5.4.1
A	2016-08-01	Added information about valid I2C addresses for the MAC address E2PROM.
B	2017-04-28	Added information that accelerometer MMA7455LT is no longer mounted.
C	2018-02-14	Added information about known issue with low speaker volume. Updated links to documents.

## 2 Introduction

Thank you for buying Embedded Artists' *LPC4357 Developer's Kit* based on NXP's ARM dual-core Cortex-M4/M0 LPC4357 microcontroller.

This document is a User's Guide that describes the *LPC4357 OEM Board* and the *OEM Base Board* hardware design, which together form the *LPC4357 Developer's Kit*.

### 2.1 Features

Embedded Artists' *LPC4357 OEM Board* lets you get up-and-running quickly. The small form factor OEM board offers many unique features that ease your learning curve and program development. The board has been designed for OEM applications with volume discount available.

- NXP's ARM dual-core Cortex-M4/M0 LPC4357 microcontroller in BGA package, with 1 MByte program FLASH and 136 KByte SRAM
- 16 MBit QSPI flash on SPIFI interface
- External FLASH memories: 128 MB NAND FLASH
- External data memory: 32 MB SDRAM (32-bit databus width)
- 12.0000 MHz crystal for maximum execution speed and standard serial bit rates, including CAN and USB requirements
- 32.768kHz RTC crystal
- 100/10M Ethernet PHY/interface based on SMSC LAN8720
- Buffered 32-bit data bus for external expansion
- 1 Kbit E2PROM with EUI-48™ number (for Ethernet MAC address)
- 200 pos expansion connector (SODIMM-200 format, 0.6mm pitch)
  - Most LPC4357 pins available (see LPC4357 OEM Board datasheet for details)
- +3.3V only powering
- Onboard reset generation
- Compact SODIMM format: 68 x 50 mm
  - Eight layer PCB design for best EMC performance, with controlled impedance and length matched routing for critical signals

There is an accompanying *OEM Base Board* that can be used for initial prototyping work. The features of the board are:

- Interfaces and Connectors
  - 200 pos, 0.6mm pitch SODIMM connector for *OEM Board*
  - LCD expansion connector with control signals for touch screen interface
  - Expansion connector with all *OEM Board* signals
  - Ethernet connector (RJ45)
  - CAN interface & connector (provision for second CAN interface, but not mounted)
  - USB1: OTG or Host interface & connector

- USB2: Device or Host interface & connector
- Provision for NXP JN5148 RF module (former Jennic) interface (RF module not included)
- Full modem RS232 (cannot be fully used on 32-bit databus OEM boards)
- RS422/485 interface & connector
- I2S audio codec (mic in, line in, line out, headphone out)
- SWD/JTAG connector
- Trace connector
- Power
  - Power supply, either via USB or external +5V DC
  - Coin cell powering supported (CR1025 battery not incl.) for RTC and LED on ALARM sig.
- Other
  - *OEM Board* current measuring
  - Parallel NOR flash on external memory bus
  - 16-bit register and LEDs on external memory bus
  - 5-key joystick
  - 3-axis accelerometer (I2C connected) - not mounted on boards after March 2017
  - LM75 temperature sensor (I2C connected)
  - 5 push-button keys (four via I2C and one on P2.10)
  - 9 LEDs (8 via I2C and one on P2.10)
  - Analog input
  - USB-to-serial bridge on UART #0 (FT232R) and ISP functionality
  - Reset push-button and LED
  - Speaker output on analog output from *OEM Board*, or from I2S audio codec
  - Compact size: 160x150 mm

## 2.2 ESD Precaution

Please note that the *LPC4357 OEM Board* and *OEM Base Board* come without any case/box and all components are exposed for finger touches – and therefore extra attention must be paid to ESD (electrostatic discharge) precaution.

***Make it a habit always to first touch the metal surface of one of the USB or Ethernet connectors for a few seconds with both hands before touching any other parts of the boards.*** That way, you will have the same potential as the board and therefore minimize the risk for ESD.



Never touch directly on the *LPC4357 OEM Board* and in general as little as possible on the *OEM Base Board*. The push-buttons on the *OEM Base Board* have grounded shields to minimize the effect of ESD.

***Note that Embedded Artists does not replace boards that have been damaged by ESD.***

### 2.2.1 ESD sensitivity on JTAG interface

Note that the LPC4357 MCU is sensitive to ESD on the JTAG port. Observe extra care around this.

***Make sure the ground of the JTAG interface is connected to the OEM Base Board ground before even connecting the JTAG interface. Never have the OEM Board unpowered while the JTAG pod is powered.***

## 2.3 General Handling Care

Handle the *LPC4357 OEM Board* and *OEM Base Board* with care. The boards are not mounted in a protective case/box and are not designed for rough physical handling. Connectors can wear out after excessive use. The *OEM Base Board* is designed for prototyping use, and not for integration into an end-product.

For boards with LCD, do not exercise excessive pressure on the LCD glass area. That will damage the display. Also, do not apply pressure on the flex cables connecting the LCD/touch screen. These are relatively sensitive and can be damaged if too much pressure is applied to them.

***Note that Embedded Artists does not replace boards where the LCD has been improperly handled.***

## 2.4 Code Read Protection

The LPC4357 has a Code Read Protection function (specifically CRP3, see datasheet for details) that, if enabled, will make the LPC4357 impossible to reprogram (unless the user program has implemented such functionality).

***Note that Embedded Artists does not replace LPC4357 OEM boards where the LPC4357 has CRP3 enabled. It's the user's responsibility to not invoke this mode by accident.***

## 2.5 CE Assessment

The *LPC4357 Developers Kit* (consisting of the *LPC4357 OEM Board* and *OEM Base Board*) is CE marked. See separate *CE Declaration of Conformity* document.

The *LPC4357 Developers Kit* is a class A product. In a domestic environment this product may cause radio interference in which case the user may be required to take adequate measures.

EMC emission test has been performed on the *LPC4357 Developers Kit*. Standard interfaces like Ethernet, USB, serial have been in use. General expansion connectors where internal signals are made available (for example processor pins) have been left unconnected. Connecting other devices to the product via the general expansion connectors may alter EMC emission. It is the user's responsibility to make sure EMC emission limits are not exceeded when connecting other devices to the general expansion connectors of the *LPC4357 Developers Kit*.

Due to the nature of the *LPC4357 Developers Kit* – an evaluation board not for integration into an end-product – fast transient immunity tests and conducted radio-frequency immunity tests have not been executed. Externally connected cables are assumed to be less than 3 meters. The general expansion connectors where internal signals are made available do not have any other ESD protection than from the chip themselves. Observe ESD precaution.

Note that the *LPC4357 OEM board* is classified as a component and is hence not CE marked separately. It can perform different functions in different integrations and it does not have a direct function. It is therefore not in the scope of the CE Directive. An end product, where an *OEM Board* is integration into, is however very likely to need CE marking.



## 2.6 Other Products from Embedded Artists

Embedded Artists have a broad range of LPC1000/2000/3000/4000 based boards that are very low cost and developed for prototyping / development as well as for OEM applications. Modifications for OEM applications can be done easily, even for modest production volumes. Contact Embedded Artists for further information about design and production services.

### 2.6.1 Design and Production Services

Embedded Artists provide design services for custom designs, either completely new or modification to existing boards. Specific peripherals and I/O can be added easily to different designs, for example, communication interfaces, specific analog or digital I/O, and power supplies. Embedded Artists has a broad, and long, experience in designing industrial electronics in general and with NXP's LPC1000/2000/3000/4000 microcontroller families in specific. Our competence also includes wireless and wired communication for embedded systems. For example IEEE802.11b/g (WLAN), Bluetooth™, ZigBee™, ISM RF, Ethernet, CAN, RS485, and Fieldbuses.

### 2.6.2 OEM / Education / QuickStart Boards and Kits

Visit Embedded Artists' home page, [www.EmbeddedArtists.com](http://www.EmbeddedArtists.com), for information about other *OEM / Education / QuickStart* boards / kits or contact your local distributor.

## 3 LPC4357 OEM Board Design

Please read the *LPC4357 OEM Board* datasheet and associated schematic for information about the board. Some additional information about the *LPC4357 OEM Board* is presented below.

### 3.1 Memory Layout

The external memory controller on the LPC4357 defines eight memory regions. See table below for details about usage.

Name	Control signal	Address range	Memories on LPC4357 OEM Board	External memory bus comment
Static memory #0	CS0	0x1C00 0000 – 0x1CFF FFFF		Available for external use. <i>OEM Base Board</i> can connect a parallel NOR flash to this chip select.
Static memory #1	CS1	0x1D00 0000 – 0x1DFF FFFF	NAND FLASH (1 GBit = 128 MByte in size)	Not available for external use. It is however possible to disable NAND flash chip by removing R25 on <i>LPC4357 OEM Board</i> .
Static memory #2	CS2	0x1E00 0000 – 0x1EFF FFFF		Available for external use. <i>OEM Base Board</i> can connect a 16-bit parallel register to this chip select.
Static memory #3	CS3	0x1F00 0000 – 0x1FFF FFFF		Available for external use.
Dynamic memory #0	DYCS0	0x2800 0000 – 0x2FFF FFFF	SDRAM (256 MBit = 32 MByte in size)	Cannot be accessed on external memory bus.
Dynamic memory #1	DYCS1	0x3000 0000 – 0x3FFF FFFF		Cannot be accessed on external memory bus.

As seen in the table above, it is only the static memory regions that are available on the external memory bus from the *LPC4357 OEM Board*. The data bus buffers on the *LPC4357 OEM Board* are controlled automatically and only enabled when a static memory region is accessed. The address and control bus buffers are always enabled.

Note that the BLS0, BLS1, BLS2 and BLS3 pins must be initialize for these functionalities. Else the buffer control will not work correctly.

#### 3.1.1 NAND Flash

Note that the NAND flash is connected after the memory bus buffers, i.e., on the same side as the *LPC4357 OEM Board* expansion signals. This is to allow flexibility in NAND flash usage and reduce loading on memory bus that is directly connected to the SDRAM.

The NAND FLASH has an optional busy output that can be used for controlling the erase/program operations with better precision. The signal is available on the expansion connector. If needed, the signal can be routed to a suitable (i.e., free) input pin. The *OEM Base Board* can connect the signal to GPIO72 by inserting a jumper between pin 3-4 on JP2. The busy status of the chip is also available under software control.

### 3.2 SPIFI

There is a 16 MBit QSPI flash connected to the SPIFI interface of the LPC4357. This memory region is available in the following address region: 0x1400 0000 – 0x1800 0000.

### 3.3 Bootloader Mode Setting

There are several boot modes for the LPC4357 microcontroller. For details, read the LPC4357 User's manual. The LPC4357 OEM board has four slider switches, JP1, where the boot mode can be set. Note that there are situations where the slider switch settings do not affect boot more. Read the LPC4357 User's manual for details about this, but in general the slider settings will be used to determine the boot mode when P2\_7 is pulled low during reset. This is accomplished by pulling pin ISP\_EN low, which in turn is accomplished by pressing SW6 on the OEM base board during reset. If signal P2\_7 is high during reset the LPC4357 boots from internal FLASH by default.

Schematic page 2 of the LPC4357 OEM board contains a list of the boot modes and associated slider settings for JP1.

LED3 on the LPC4357 OEM board is connected to signal P1\_1-A6-BS0, and is used by the microcontroller to signal possible errors during booting. LED3 will flash with a 1 Hz rate for 60 seconds if the boot process fails. After 60 seconds, the device is reset.

Slider switch JP1 is found on the top side of the LPC4357 OEM board, in the upper left corner.

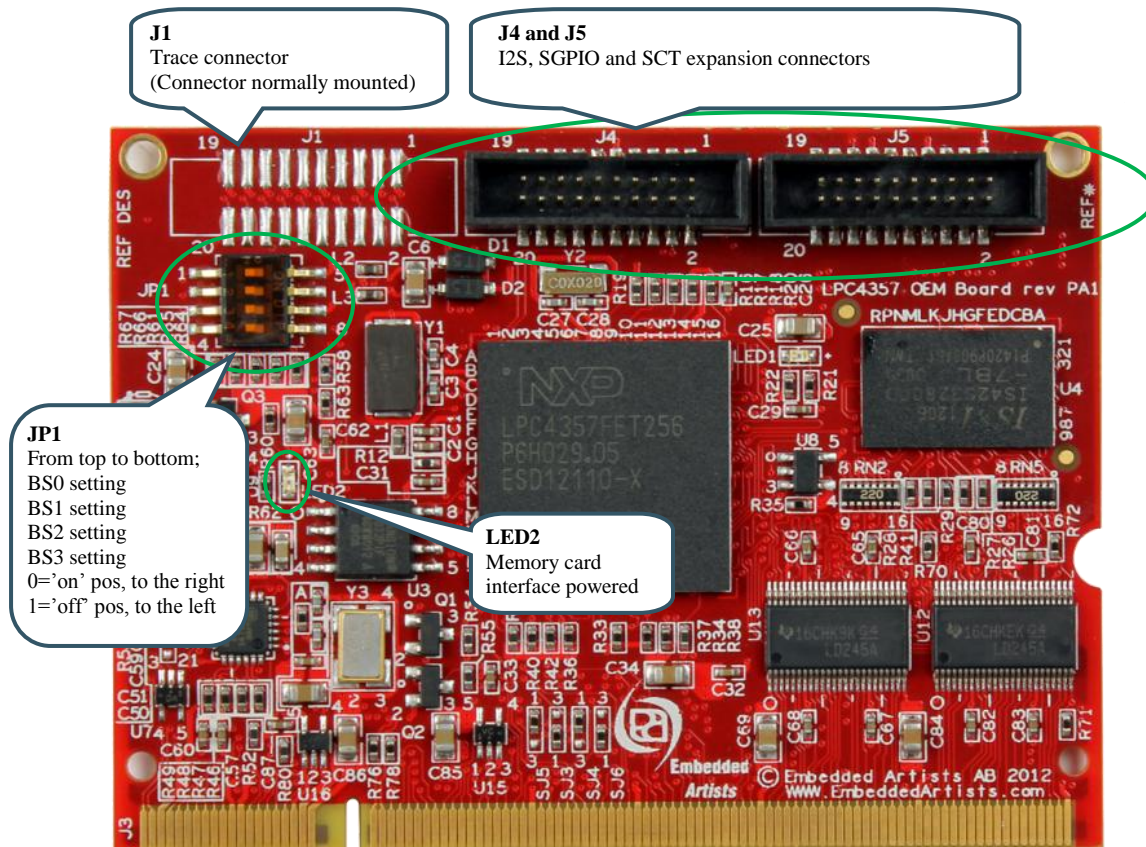

Figure 1 – LPC4357 OEM Board Picture, top side

### 3.4 Trace Connector

There is a connector on the top side of the LPC4357 OEM board, carrying all signals needed for debugging with trace. It is a standard 20 pos (50 mil pitch) trace connector as defined by ARM. Figure 1 illustrates where J1 is located on the board.

There is a trace connector on the OEM Base Board also, but this shall not be used for trace on the LPC4357. It was not possible to get compatible pinning with other OEM boards. Instead J1 was added to the design to support trace. Debugging without trace can be done either via J1 (on the LPC4357 OEM board) or the 10 pos debug connector (J7) on the OEM Base Board.

### 3.5 I2S and SGPIO Connectors

There are two 20-pos, 50 mil pitch connectors on the top side of the LPC4357 OEM board. See Figure 1 for location. These connectors carry selected I2S, I2C, SGPIO and SCT signals and can be used to connect these signals to a separate expansion boards. For example an audio and video expansion board. Note that some of the signals can be used on the OEM base board. Before using the signals, always check for possible contentions.

### 3.6 uSD Memory Card Interface

There is a uSD/transflash memory card interface connector, J2, on the bottom side of the board. See Figure 2. LED2, on the top side, lights when the interface is powered. See Figure 1 to locate LED2.

The signals on the SODIMM edge connector that are normally allocated for memory card interface (on other OEM boards) carry other signals on the LPC4357 OEM board that have no relation to the memory card interface.

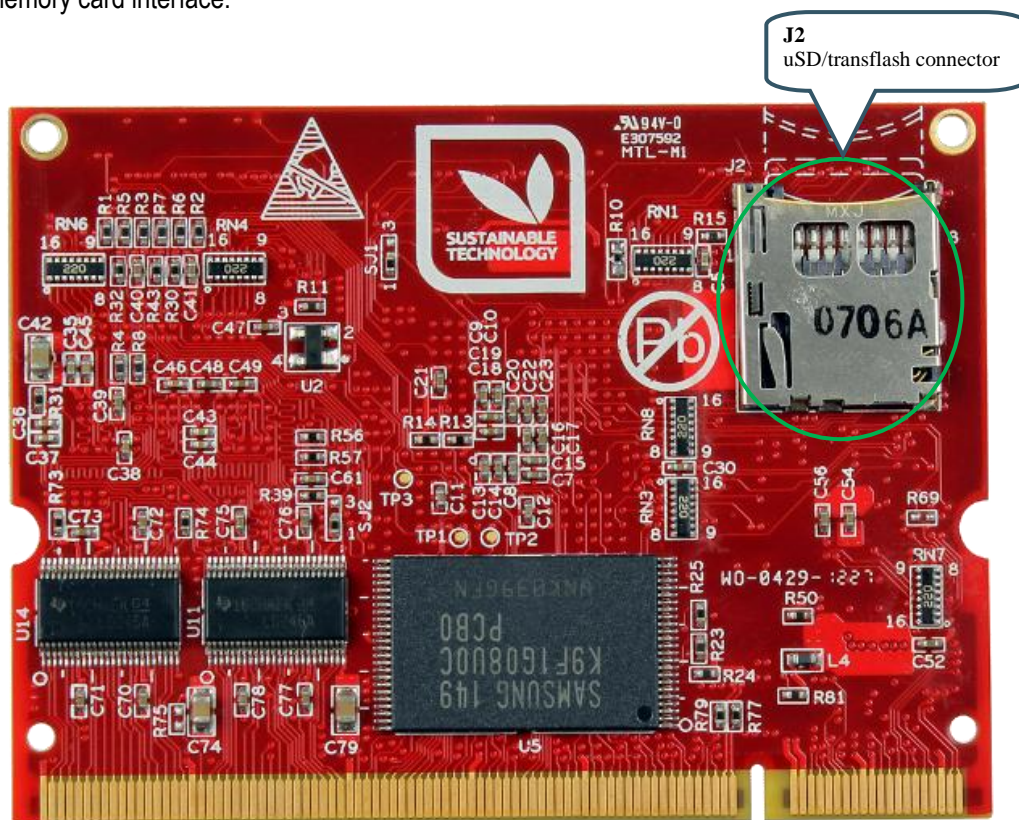

Figure 2 – LPC4357 OEM Board Picture, bottom side

### 3.7 Board Options

The schematic for the *LPC4357 OEM Board* show some different mounting options, mainly via Sx jumpers but also some resistors that are not mounted per default. The design has been prepared for customized versions for different needs.

### 3.8 1 kBit I2C E2PROM with EUI-48™ Number

The *LPC4357 OEM Board* contains a small E2PROM, 24AA02E48 from Microchip that can be accessed via I2C. The chip contains a globally unique 48-bit number (EUI-48™) that can be used as Ethernet MAC address. See the 24AA02E48 datasheet for details.

**Note that the E2PROM answers on all I2C addresses in the range 0xA0-0xAF (and not only to address 0xA0/0xA1).**

## 4 OEM Base Board Design

This chapter contains information about the peripherals and general design of the *OEM Base Board* and how to set the different jumpers on the board. The schematic can be downloaded in pdf format from the support page, and is recommended to have printed out while reading this chapter.

Section naming begins with *SPx*, which is short for *Schematic Page x*.

The picture below gives an overview of the *OEM Base Board* design.

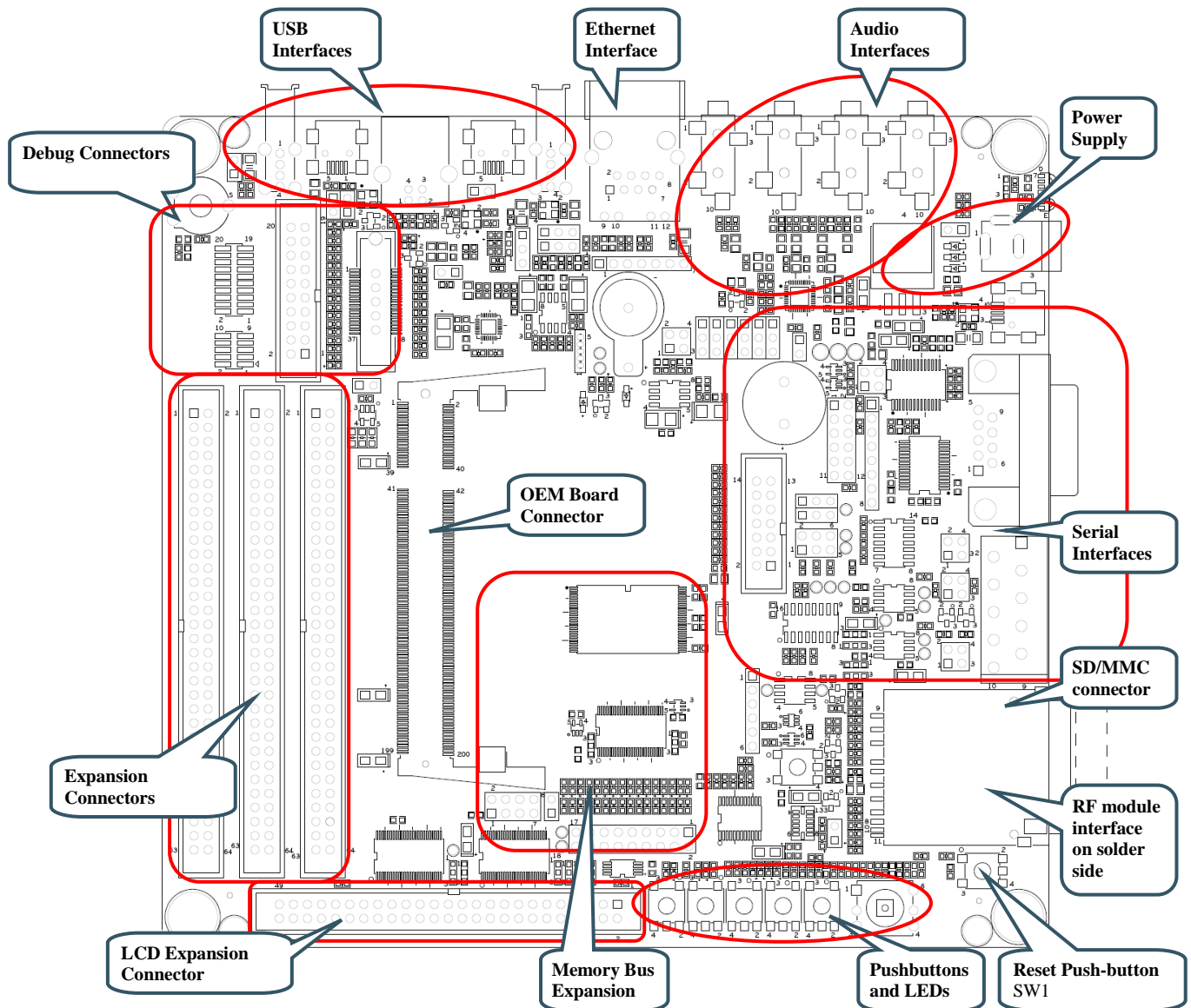

Figure 3 – OEM Base Board Overview

### 4.1 Modifications to OEM Base Board

The *OEM Base Board* has been designed to be flexible. Most options can be controlled via jumpers but some options might need soldering. Note that modifications to the board are done at own risk and void all warranties.

## 4.2 SP2: OEM Board Connector

The LPC4357 OEM board connector is a standard DDR2 SO-DIMM socket with 200 positions and 0.6mm pitch. It has 1.8V keying (which is what DDR2 stands for). The JEDEC standard defining the DDR2 SODIMM boards is called JEDEC MO-224.

The signal names are general and represent the OEM base board functionality, rather than the LPC4357 signal names. This is because the OEM base board also supports other OEM boards.

## 4.3 SP2: Current Measurements

It is possible to accurately measure current consumption of the LPC4357 OEM board. This can be very valuable when working with applications that make use of the low power modes of the LPC4357 processors. The circuit is based on the chip ZXCT1010 from Diodes/Zetex. This chip generates a voltage output proportional to the current through R2. This voltage can be measured over J2. 100mA gives a 500mV output voltage, or expressed differently, 1mV correspond to 0.2mA

It is possible to remove R1, R2 and/or R3 for measuring current with an external multimeter. Note that VCC\_MAIN and VCC\_BUFFERS are connected on the LPC4357 OEM board so there is no difference between these supplies. This division has been done for compatibility with other OEM boards.

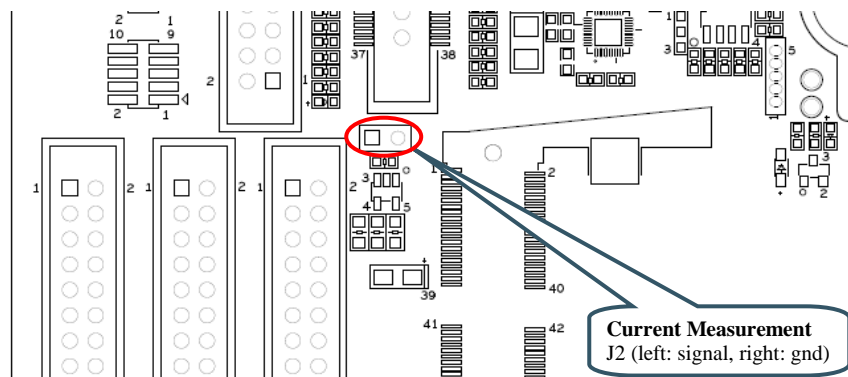

Figure 4 – Current Measurement J2

## 4.4 SP3: Expansion Connectors

All relevant OEM board signals are available for external use via three 64 pos IDC expansion connectors; J3, J4 and J5. The expansion connectors are close to the SO-DIMM connectors to minimize signal distortion.

Note that some OEM board circuits may need to be disconnected before externally used. Carefully investigate the need for this before using a signal for external expansion.

Note that J4 has gathered all needed signals for expanding the memory bus (16-bit bus expansion). J4 is the expansion connector closest to the board edge. For 32-bit memory bus expansion, J3 is also needed (for the upper 16 bits of the databus).

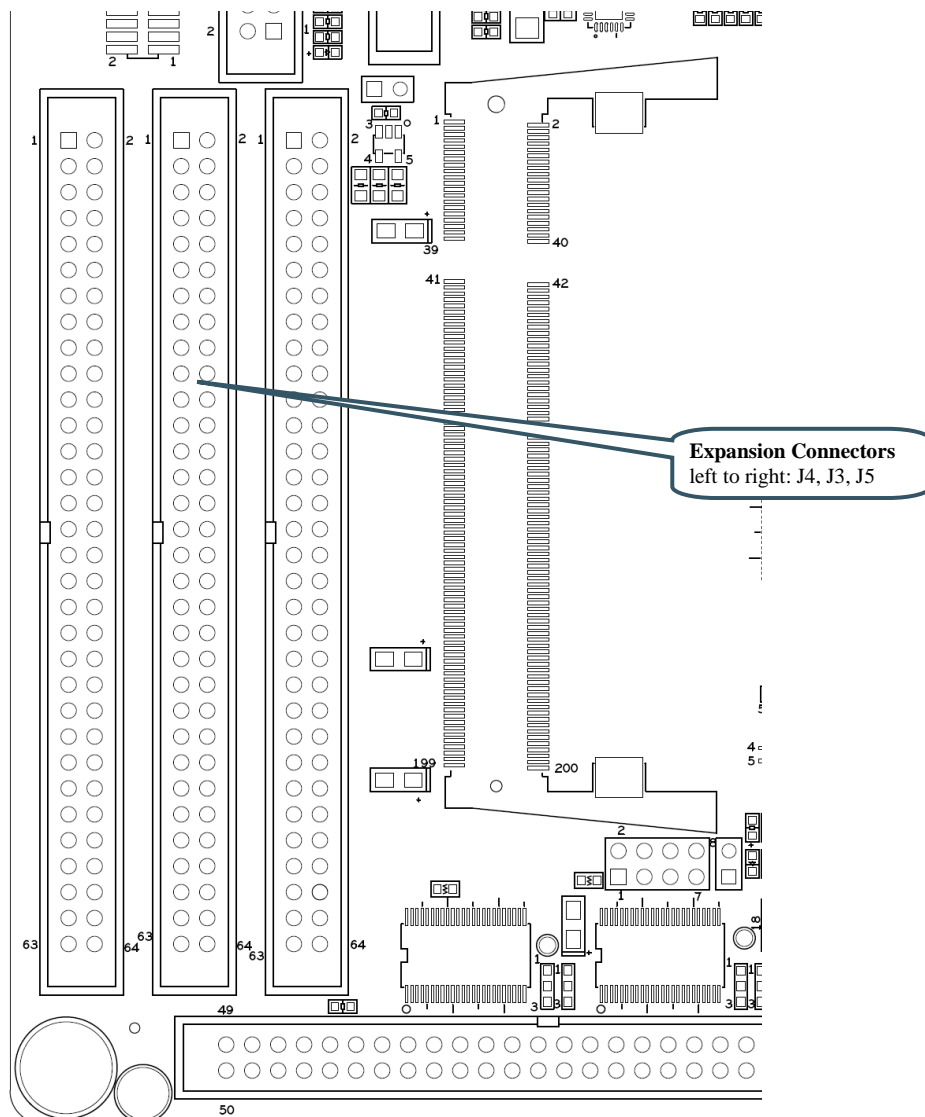

Figure 5 – Expansion Connectors J3, J4, J5

## 4.5 SP4: External Memory Bus

This part of the OEM Base Board demonstrates how the external memory bus can be used for expansion of custom circuits. Two different devices are connected to the memory bus; a 16-bit parallel NOR flash and a 16-bit register.

In order to be universal between 16- and 32-bit databus width OEM Boards, only the lower 16 bits are connected.

The 16-bit parallel NOR flash is enabled when JP1 is inserted, see picture below for guidance where to find JP1 on the OEM Base Board. Note that the signal name is cryptic since the OEM Base Board is compatible with many different OEM Board. For the LPC4357 OEM Board, the signal BCSY is actually signal BCS0. This means that the NOR flash is accessible in memory region: 0x1C00 0000 - 0x1CFF FFFF.

Also, a 16-bit register is connected to the external memory bus. The 16 bits in the register directly drives 16 LEDs (a high signal light a LED). The signals are also available on an expansion connector (J6). It can for example connect to a logic analyzer, for high-bandwidth logging. The upper and lower 8 bits are individually writeable. Signals BBS0/BBS1 controls the lower and upper 8 bits, respectively. Since the OEM Base Board is universal and supports many different OEM Boards, the chip select signal is either signal BCSX or GPIO69. For the LPC4357 OEM Board, the signal BCSX is actually



signal BCS2. This means that the register is accessible in memory region: 0x1E00 0000 - 0x1EFF FFFF. No jumper in JP2 is needed when working with the LPC4357 OEM Board.

SJ12 shall be in default position (pad 1-2 shorted) to let BCS2 control chip select of the 16-bit register.

SJ1 controls the output enable of the register. By default it is grounded (pad 1-2 is shorted) and hence the register drives the LEDs and expansion connector, J6.

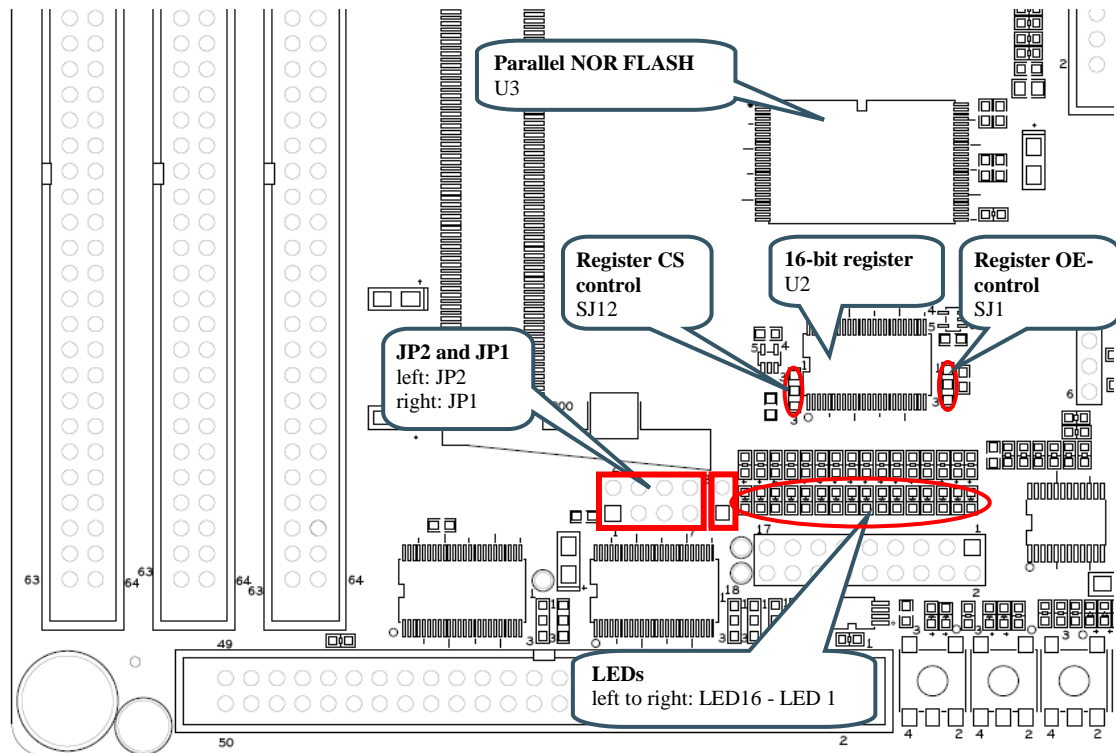

Figure 6 – External Memory Bus Circuit

## 4.6 SP5: Debug Interfaces

Note that the LPC4357 MCU is sensitive to ESD on the JTAG port. Observe extra care around this.

***Make sure the ground of the JTAG interface is connected to the OEM Base Board ground before even connecting the JTAG interface. Never have the OEM Board unpowered while the JTAG pod is powered.***

The multiple debug interfaces can look complex, but that is just because the board supports many different OEM Boards. The connectors are:

- J7 – this is the new and smaller footprint standard ARM debug connector. It has 2x5 pins in 50 mil pitch. The connector supports both the SWD and JTAG interfaces. Note that not all, and in particular older, JTAG debug probes do not support the SWD interface standard. Note where pin 1 is found (see picture below) for this connector.
- J8 – this is the old and big footprint standard ARM debug connector. It has 2x10 pins in 100 mil pitch. The connector supports both the SWD and JTAG interfaces. Note that not all, and in particular older, JTAG debug probes do not support the SWD interface.
- J9 – this is the old and big footprint 38 pin Mictor connector for ETM trace for the LPC2478. This connector is not mounted. It is not used when working with the LPC4357 OEM board. The connector can be soldered to the board if needed. The connector can be bought from

Tyco Electronics Amp and is a 38-way receptacle Mictor connector, 0.025" pitch, part number: 767054-1 or 2-5767004-2 (RoHS compliant).

- J10 – this is the new and smaller footprint standard ARM Cortex-M3/M4 connector for trace. It carries the trace signals as well as the debug signals found on J7. **Note that this connector is not used when working with the LPC4357. Instead a 20 pos trace connector, J1, exists on the LPC4357 OEM board itself.**

When working with the LPC4357 OEM Board, J7 is typically used. If an older and big footprint JTAG debug pod is used, J8 can alternatively be used.

If trace is also used, use the connector J1 on the LPC4357 OEM board. Note that this requires an advanced JTAG probe that supports trace.

**Note that JP4 shall be shorted in order to enable the JTAG/SWD interface on the LPC4357.** JP4 might not be inserted by default on the OEM Base Board.

JP3 is not used for debug purposes when working with the LPC4357 OEM Board.

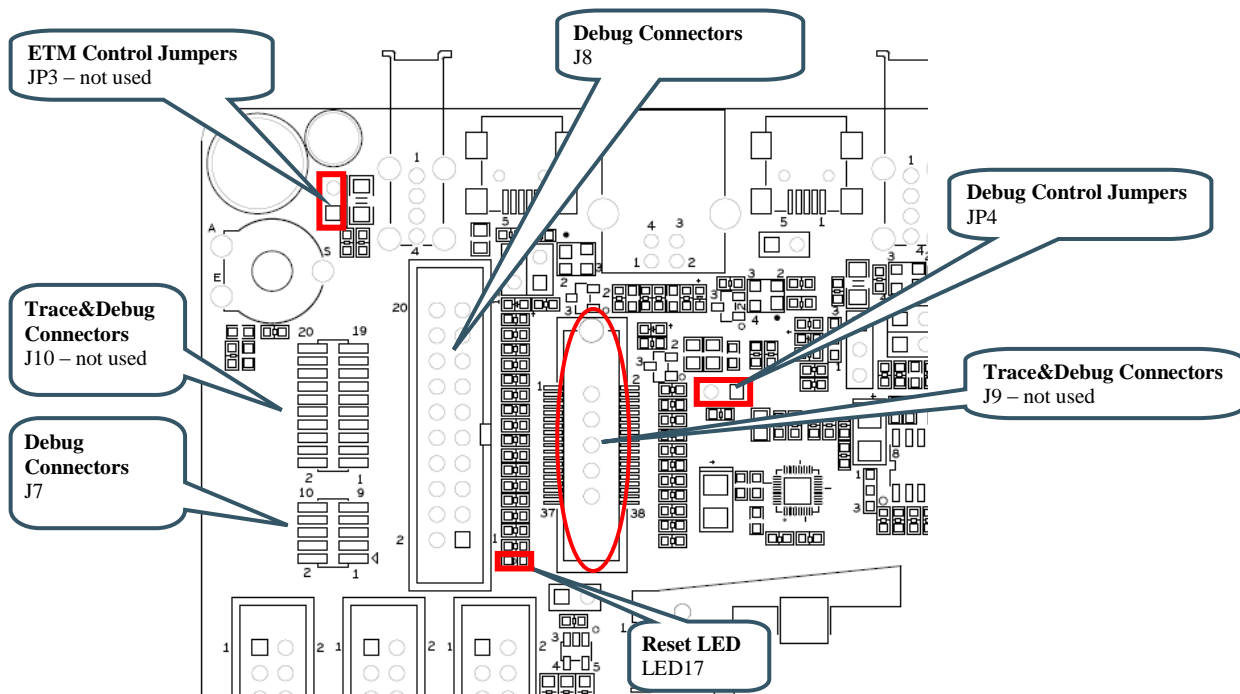

Figure 7 – Debug Interfaces

## 4.7 SP6: Ethernet Interface

The board has an Ethernet interface, J11, which is a RJ45 connector with integrated magnetics. There is also provision on the board for connecting a PoE interface. All signals can be accessed via expansion pads, J12. Five 0 ohm resistors have to be removed in that case for isolating J11 from the new connector (this is because J11 is not capable of handling a PoE interface so a new RJ45 connector must be added). See picture below for where to find the relevant components on the board.

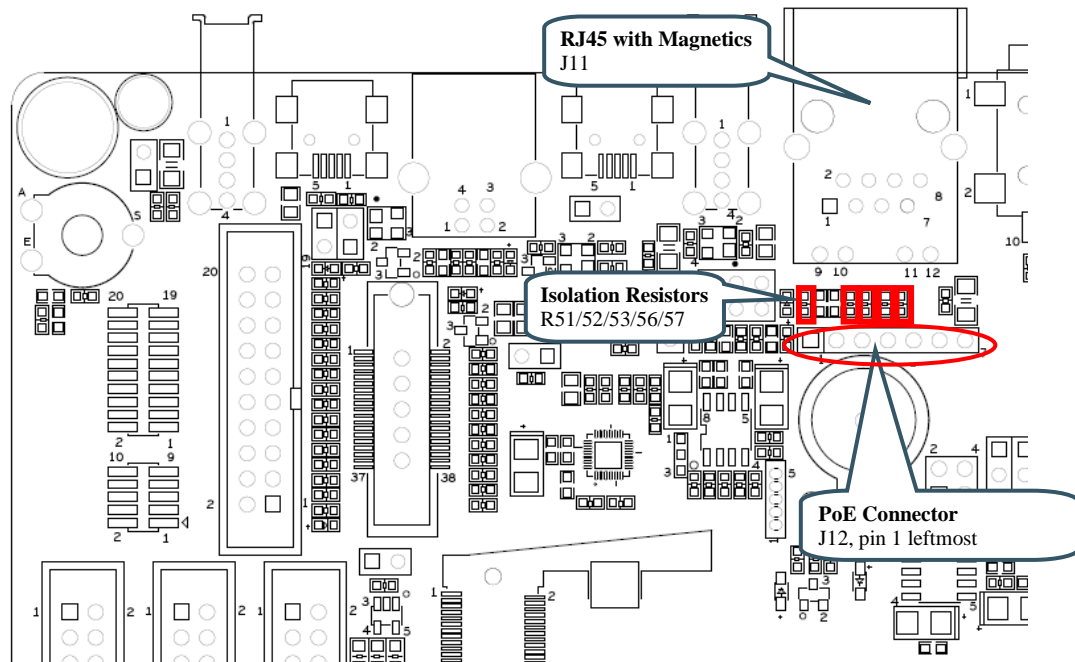

Figure 8 – Debug Interfaces

PoE modules that can be used for testing can for example be found at [http://www.silvertel.com/poe\\_products.htm](http://www.silvertel.com/poe_products.htm). Select a version delivering +5V with enough current capability for the specific application in mind. For example, using USB Host with power hungry external devices will require more current. In most situations a 9-10W module will be sufficient.

Besides the PoE module, a RJ45 capable of handling PoE is also needed.

#### 4.8 SP6: SD/MMC Memory Card Interface

The board has a SD/MMC memory card interface, J13. Note that this interface **SHALL NOT** be used for accessing the MCI peripheral interface of the LPC4350. Instead, there is a uSD/transflash memory card interface on the bottom side of the LPC4357 OEM board.

There is visual indication via LED2 on the LPC4357 OEM board that supply voltage to the memory card is present.

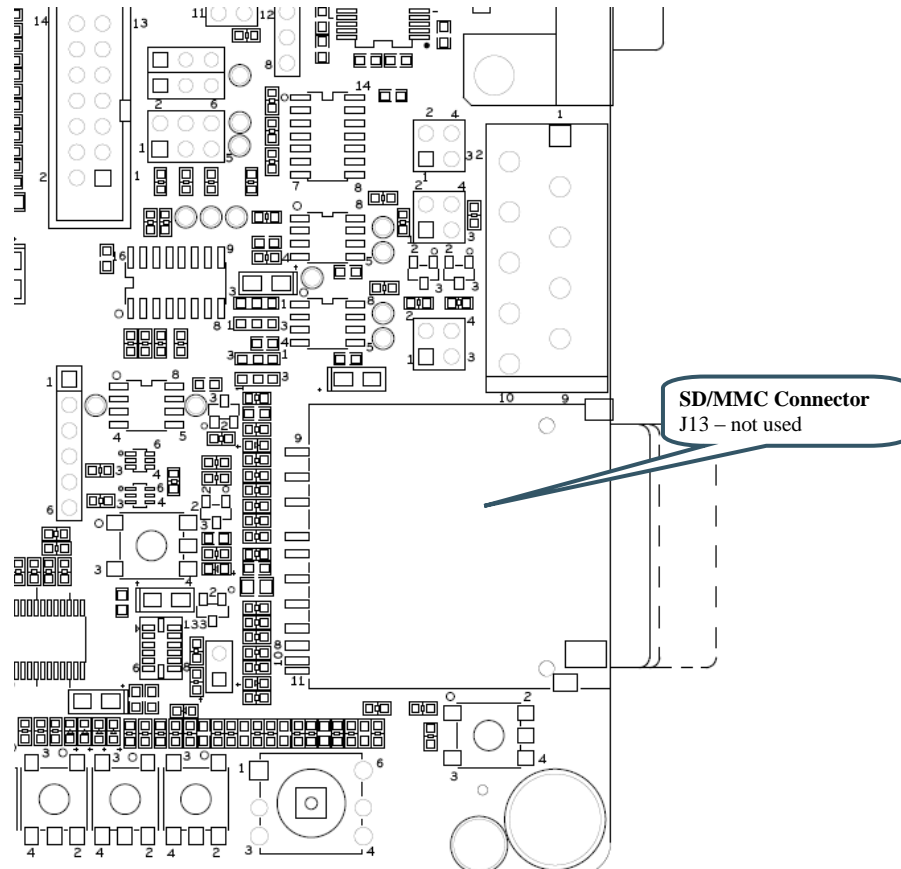

Figure 9 – SD/MMC Memory Card Interface – Not used

#### 4.9 SP6: VBAT/ALARM Handling

The board can power the VBAT input supply (to the OEM board) from two different sources:

- The +3.3V power supply, via D1 (when board is normally powered).
- A 3V Lithium CR1025 size coin battery, via D2. Note that battery is not included.

See the LPC4357 datasheet for details about VBAT voltage range.

The ALARM signal control LED21. Note that LED21 will consume a lot of current from the battery and/or super-capacitor. Restrict on/high time to preserve energy.

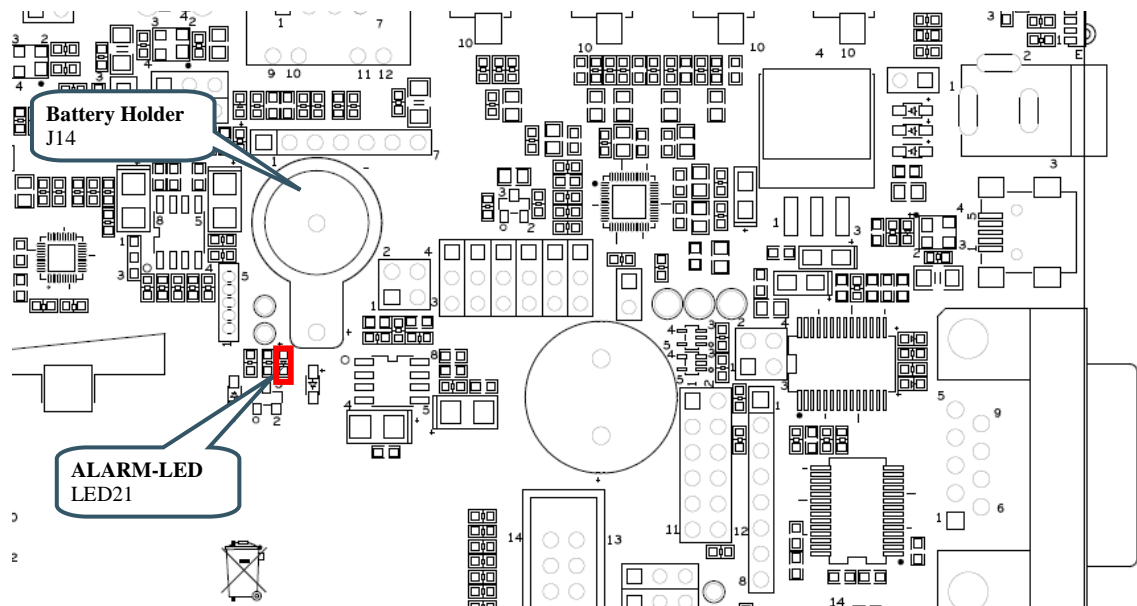

Figure 10 – VBAT and ALARM circuit

#### 4.10 SP7: I2C Peripherals

There are several I2C peripherals on the board. See picture below for locating the different components on the board. The I2C addresses for the individual components are given in the schematic.

- Configuration E2PROM, 64kbit. This chip contains version information about the OEM Base Board.
- LM75 Temperature sensor.
- 3-axis Accelerometer (MMA7455). Note that the two interrupt outputs are not connected but available on JP5. **Note** that because the accelerometer is obsolete, it is not mounted on boards after March 2017.
- Port expander (PCA9532) with 8 LEDs and 4 pushbuttons. The Card Detect and Write Protect signals from the SD/MMC memory card connector are also connected to this chip. LED22/23 are positioned above SW2, LED24/25 are positioned above SW3, LED26/27 are positioned above SW4 and LED28/29 are positioned above SW5.

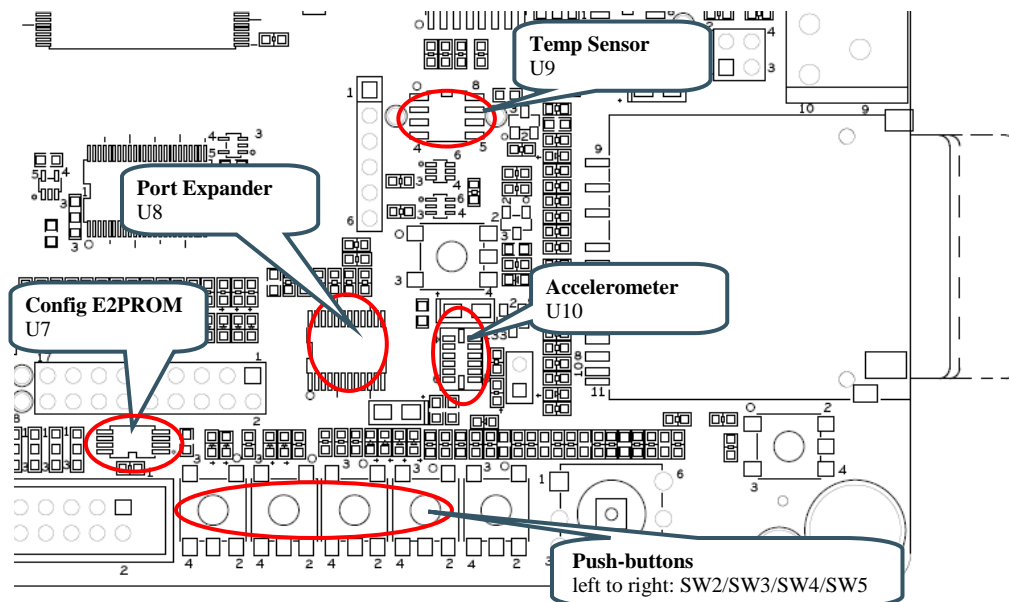

Figure 11 – I2C Peripherals

Signals	LPC4357
I2C-SDA	I2C-SDA
I2C-SCL	I2C-SCL

#### 4.11 SP8: Analog Input

The board contains a trimming potentiometer (R94) for manually generating an adjustable voltage (between GND and VREF). See picture below where to locate the trimming potentiometer on the board. The table list which pin the adjustable voltage is connected to.

**It is recommended to remove resistor R93 on the OEM base board** in order to be able to use signal ADC6. In order to be compatible with other OEM boards, R93 connects signal V3A and VREF, but signal VREF is carrying signal ADC6 on the LPC4357 OEM board.

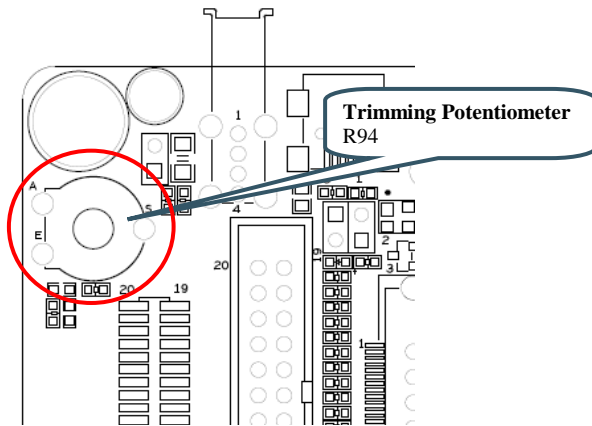

Figure 12 – Analog Input

Signals	LPC4357
GPIO39_AIN2	ADC3

## 4.12 SP8: Digital IO

There is a push-button (SW6) that is connected to a signal that enable the ISP-mode after reset on the OEM Board. For the LPC4357 this is pin P2\_7. If this pin is sampled low after reset, the ISP-mode for the LPC4357 is entered. LED30 is positioned above SW6 and will light when SW6 is pressed. It is also possible to control LED30 as an output from the OEM Board without damaging the output driver when SW6 is pressed. R110 limits the current.

There is also a 5-key joystick that directly connects to five general purpose input/output pins. See picture below for locating SW6 and SW7.

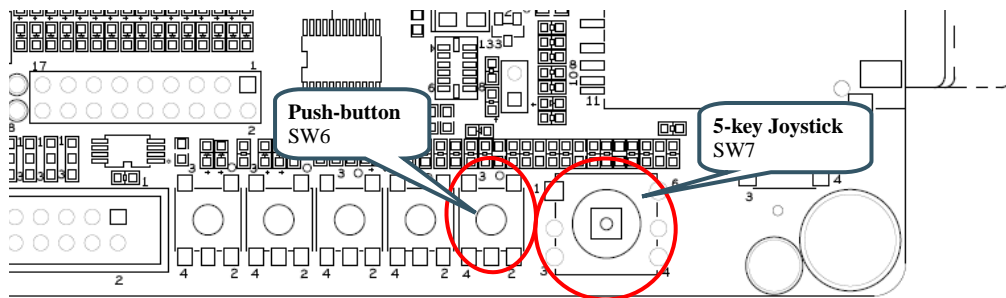

Figure 13 – Digital IO

Signals	LPC4357
GPIO_10	Open collector driver on P2_7. This signal is an input only on the the LPC4357 OEM board and can only be used to pull P2_7 low, i.e., enable ISP mode after a reset.
GPIO_73	PA_1
GPIO_74	PA_2
GPIO_75	PA_3
GPIO_76	P9_0
GPIO_77	P9_1

## 4.13 SP8: Serial Expansion Connector

The *Serial Expansion Connector* is a standardized serial interface connector that is included on many boards from Embedded Artists, including the OEM Base Board. The purpose is to provide a simple expansion connector for smaller expansion modules. Such modules are typically sensors of different kinds and communication modules, but can also be smaller displays.

The connector contains 14 pins that support SPI, UART and I2C communication. Four additional pins exist for specific functionality, like module reset, interrupt pins, analog signals and pwm signals. Power (3.3V) is also provided. Maximum current consumption of the external module is 250mA. All signals are protected with 470 ohm series resistors to minimize current in case of shorts to ground, +3.3V, or similar.

Usage of the different signals is specific for each module connected. All signals can be configured as either main function or alternatively as a general purpose input/output signal (GPIO). The picture below show where the connector can be found and the table lists which pins are connected. The application program has the responsibility to program the individual pins to correct state/function.

Note that the UART channel is not directly connected to USART channel #3 on the LPC4357. It is multiplexed with other UART channels, see section 4.15 for details. Also note that the *Serial Expansion*



Connector and the RF-module (see section 4.14 ) share the same UART channel. Once the RF module is soldered, the *Serial Expansion Connector* cannot be used for UART communication.

**Also note that pin 13 and 14 on the Serial Expansion Connector, J15, are connected to ADC1 and ADC2, respectively. These pins are input only on the LPC4357. In order to have GPIO functionality on these two pins on J15, other GPIO signals has to be wired to these pins.** This can easily be done at the J3, J5 and J5 connectors. For example, pin 27 and 29 of J3 can be shorted/connected. That way, signal MCICMD (carrying LPC4357 pin PC\_11) is connected to GPIO38\_AIN1. Pin 21 and 23 of J5 can also be shorted/connected. That way, signal GPIO33\_LCD-DC (carrying LPC4357 pin P4\_0) is connected to GPIO37\_AIN0.

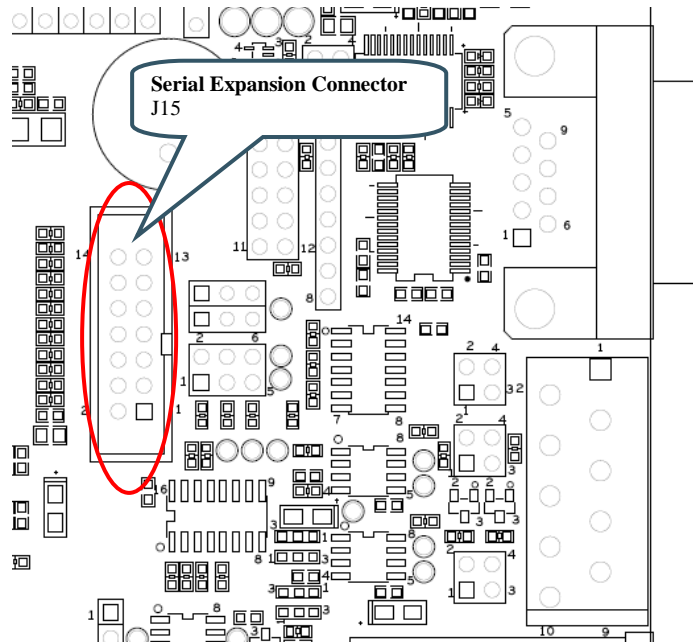

Figure 14 – Serial Expansion Connector

Signals	LPC4357
GPIO29_SPI-CLK	PF_0, SSP0 is used
GPIO31_SPI-MISO	PF_2, SSP0 is used
GPIO32_SPI-MOSI	PF_3, SSP0 is used
GPIO69	P9_2
SIE_UART_RXD	P2_4 via multiplexor, USART#3 is used
SIE_UART_TXD	P9_3 via multiplexor, USART#3 is used
I2C-SCL	I2C-SCL
I2C-SDA	I2C-SDA
GPIO42	P9_6
GPIO72	PC_2
GPIO37_AIN0	ADC1  <b>This is pin 13 of J15. It is suggested to short pin 27 and 29 of J3 in order to connect LPC4357 pin PC_11 to this signal – to get GPIO functionality on this pin.</b>

GPIO38_AIN1	ADC2  <b>This is pin 14 of J15. It is suggested to short pin 21 and 23 of J5 in order to connect LPC4357 pin P4_0 to this signal – to get GPIO functionality on this pin.</b>
-------------	---

#### 4.14 SP8: NXP/Jennic RF Module Interface

There are pads on the backside of the OEM Base Board for soldering a JN5148 NXP (former Jennic) RF module. These pads are opposite of the SD/MMC memory card interface connector. There is also provision on the board for programming the RF module. This is done via 6-pos pin list (J31) where a FTDI programming cable is connected (TTL to USB Serial Converter cable, TTL-232R-3V3, see for example Digkey: 768-1015-ND). During programming, multiplexor U29 and U30 connects the UART channel directly to the programming cable, via J31. The RF-module can be reset via SW1. Program mode is entered by pressing SW9 during (and shortly after) reset.

Note that the UART channel is not directly connected to a UART channel on the LPC4357. It is multiplexed with other UART channels, see section 4.15 for details. Also note that the *Serial Expansion Connector* (see section 4.13 ) and the RF-module share the same UART channel. Once the RF module is soldered, the *Serial Expansion Connector* cannot be used for UART communication.

See picture below for locating the relevant components on the board. See also the table for signal connection.

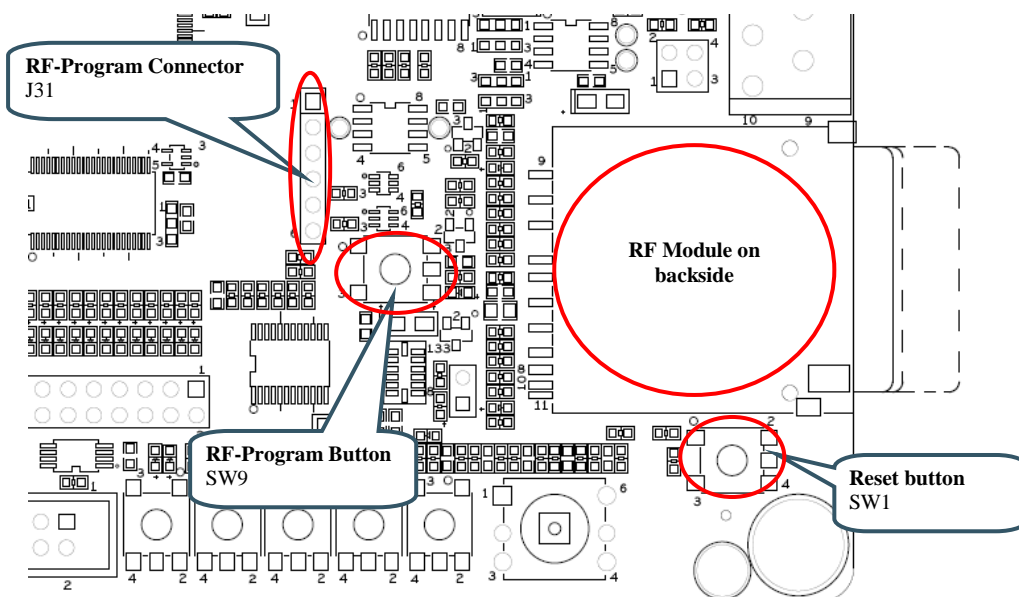

Figure 15 – RF Module

Signals	LPC4357
SIE_UART_RXD	P2_4 via multiplexor, USART#3 is used
SIE_UART_TXD	P9_3 via multiplexor, USART#3 is used

### 4.15 SP9: UART Multiplexing

UART channels from four sources are multiplexed into one UART channel, which is connected to the OEM Board:

- Serial Expansion Connector / RF module. Note that if the RF module is soldered to the board, then UART channel on the Serial Expansion Connector is occupied.
- LCD Expansion connector
- RS422/485 Interface
- RS232 Interface

The multiplexing is static, in the sense that a change in the multiplexor setting requires jumpers to be moved. It is not controlled from the OEM Board. The picture below shows where to find the pin list to control multiplexing and the different settings. The table lists signal connection.

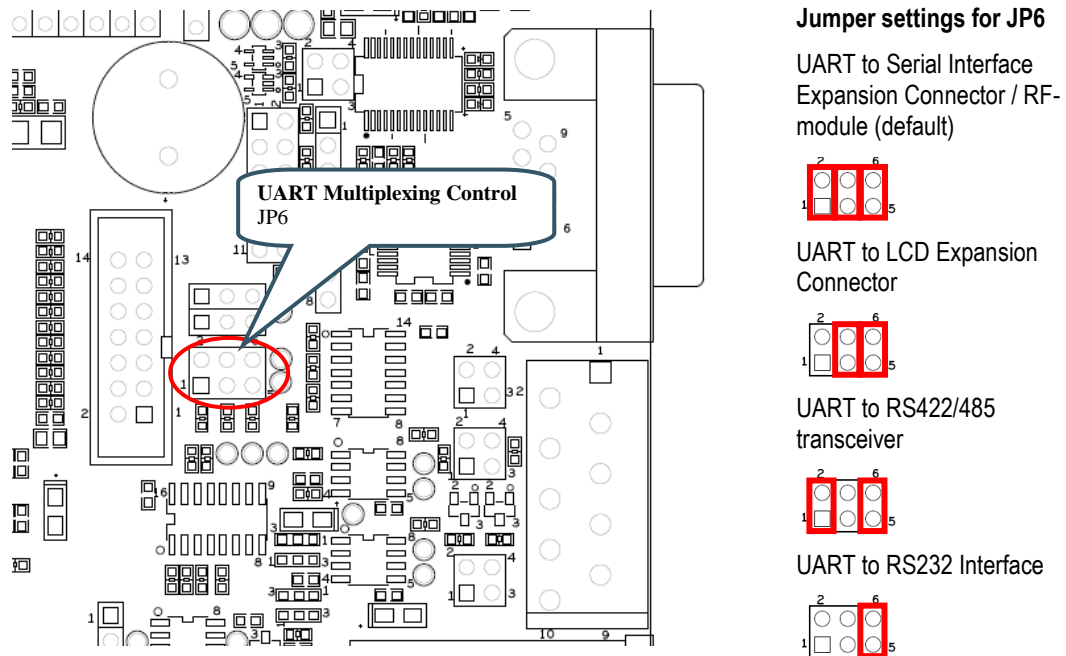

Figure 16 – UART Multiplexing

Signals	LPC4357
GPIO25_RXD	P2_4 via multiplexor, USART#3 is used
GPIO24_TXD	P9_3 via multiplexor, USART#3 is used

#### 4.16 SP9: RS232 Interface

There is a RS232 interface with all modem signals on the board. The RS232 interface is available on a 9-pos male DSUB. The OEM Base Board is a DTE (Data Terminal Equipment). An external device can be a DCE (Data Communications Equipment). For connecting DTE-to-DCE a straight-thru cable shall be used. An external device can also be a DTE. For connecting DTE-to-DTE a null-modem cable shall be used (also called a crossover cable).

See picture below for locating relevant components on the board. The table below lists signal connections. Note that for the LPC4357 OEM board, which has 32-bit databus, the UART signals (Rx/Tx and modem signals) are not available at the same place as other OEM boards. The upper half of the databus occupies the signals used in this interface. Therefore, J18 has to be used to allow custom connection of the signals needed. The needed signals can be wired from J3, J4 and J5.

Note that it is possible to connect just the RxD/TxD UART signals to the UART multiplexor (USART#3 used) by placing jumpers in position 2-3 in JP12 and JP13. In this case, it will not be a full modem RS232 interface but RxD/TxD will still be available.

The interface component used (SP3243E) has built-in ESD protection.

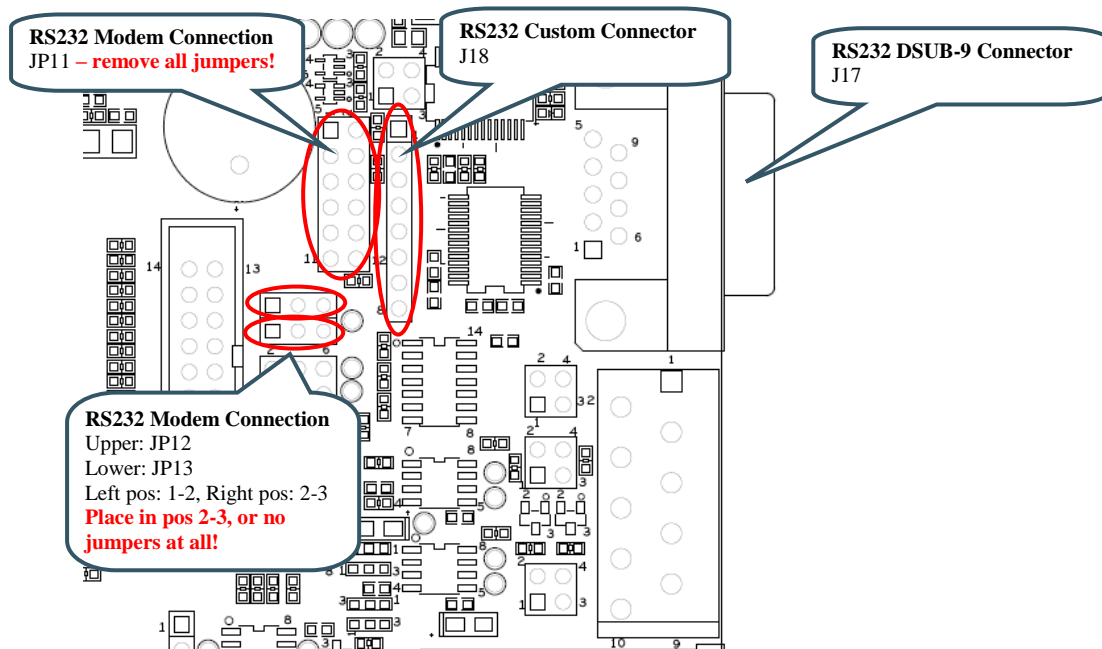

Figure 17 – RS232 Interface

Signals	LPC4357
GPIO25_RXD	P2_4 via multiplexor, USART#3 is used
GPIO24_TXD	P9_3 via multiplexor, USART#3 is used

### 4.17 SP9: RS422/485 Interface

There is a RS422/485 interface on the board. RS422 has individual transmit and receive pairs, while RS485 share the same signal pair (and is hence half-duplex). By inserting both jumpers in JP9, the two signal pairs are connected and a RS485 interface is created. By removing the jumpers in JP9 a RS422 interface is created. Via JP10 it is also possible to add termination resistors, if needed.

Direction is controlled via signal GPIO43 and is by default half-duplex (i.e., no simultaneous transmit and receive). A high level enables the transmitter while a low level enables the receiver. It is possible to remove R135 and R136 and control the transmitter and receiver individually via JP7 and JP8.

The interface component used (SN65HVD35) has built-in ESD protection.

See picture below for locating relevant components. The table below lists signal connections.

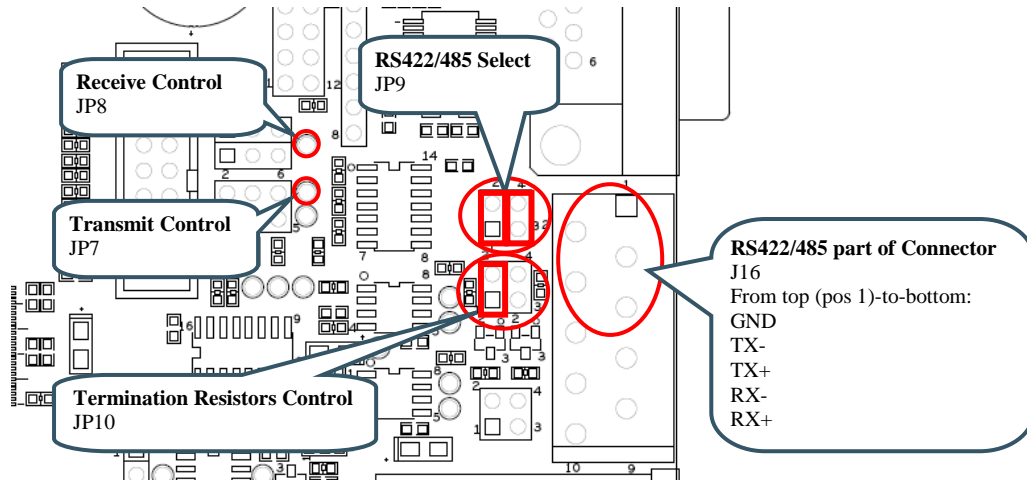

Figure 18 – RS422/484 Interface

Signals	LPC4357
GPIO25_RXD	P2_4 via multiplexor, USART#3 is used
GPIO24_TXD	P9_3 via multiplexor, USART#3 is used
GPIO43	PF_6

#### 4.18 SP10: CAN

There is one CAN interface mounted on the board. The board is also prepared for a second CAN interface, but this cannot be used with the LPC4357 OEM board. Via JP16 it is also possible to add termination resistors, if needed. The interface has on-board ESD protection.

See picture below for locating relevant components. The table below lists signal connections.

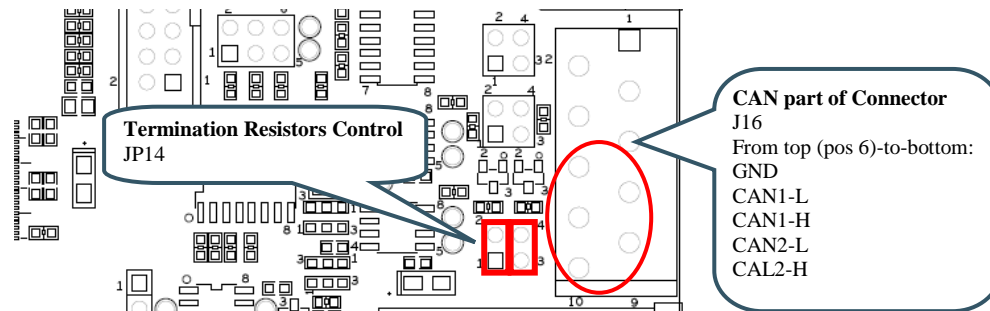

Figure 19 – CAN Interface

Signals	LPC4357
GPIO14_CANRD	P3_1, CAN0 is used
GPIO15_CANTD	P3_2, CAN0 is used
GPIO18_CANRD	P4_1, but do not carry any CAN signals
GPIO19_CANTD	P4_4, but do not carry any CAN signal

#### 4.19 SP10: IrDA

The board is prepared for an IrDA interface, but the IrDA transceiver (TFBS4652) is not mounted.

Note that the pinning of the LPC4357 OEM board is not compatible with the IrDA interface, which cannot be used.

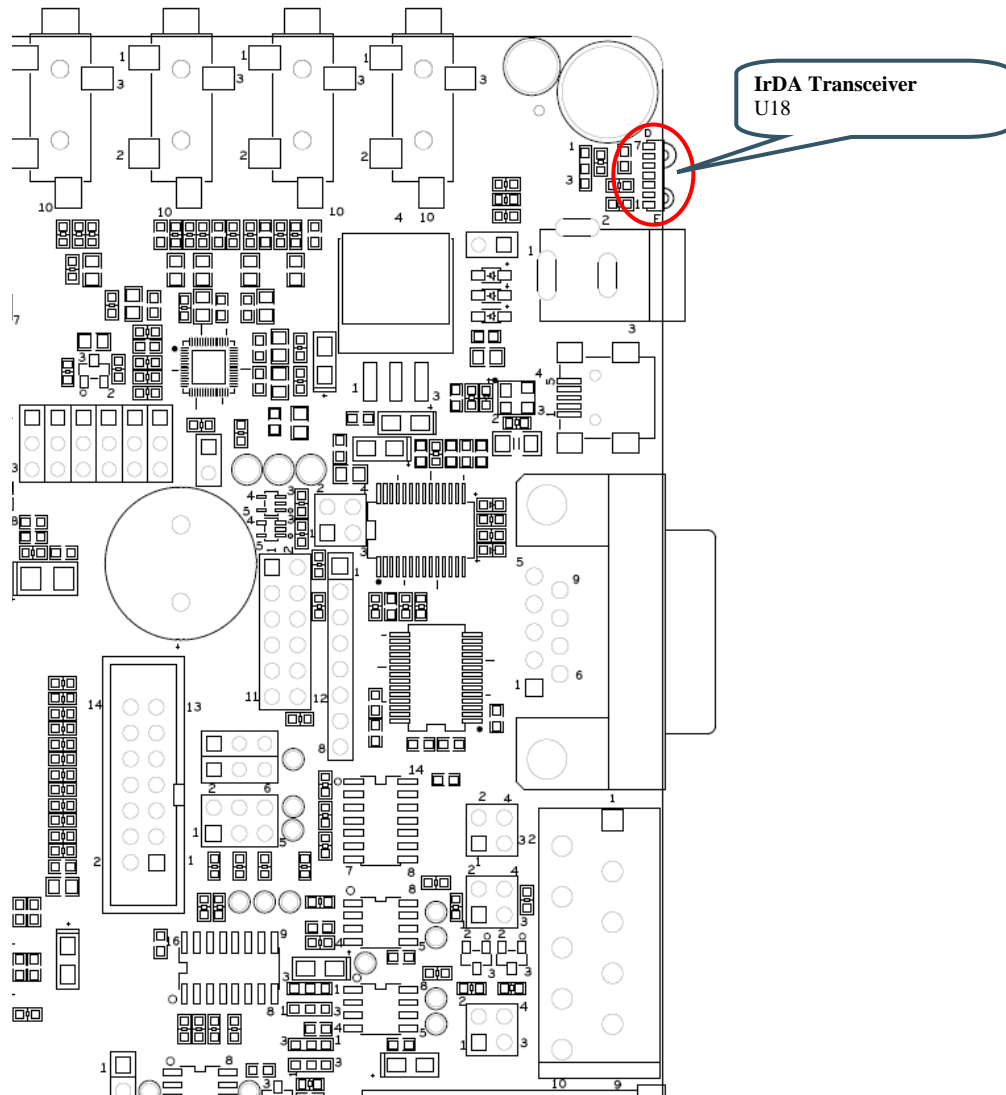

Figure 20 – IrDA Interface

### 4.20 SP11: USB Channel 1

The board contains two USB interfaces. This section covers the first (#1) that offers a USB Host or USB OTG interface. Only one of these interfaces can be used at a time, i.e., both cannot be used simultaneously. The software on the LPC4357 OEM Board is also different between the two interfaces.

This interface is connected to the USB1 interface on the LPC4357.

There is an external USB OTG transceiver, U31. This transceiver is used for OTG specific signaling but also for controlling the 1.5Kohm pull-up and 15Kohm pull-down resistor control that is needed for USB Host/Device. If just USB Device is needed, it is possible to insert a jumper in JP15 to statically connect a 1.5Kohm pull-up resistor to the USB-DP signal. LED31 can be used to signal USB-up state.

USB Host power is controlled via distribution switch U20. Pads 1-2 on SJ5 are by default connected to always enable +5V on VBUS channel 1. LED34 light whenever +5V is present on VBUS1. VBUS feedback via GPIO46 is by default disconnected as well as status feedback from the distribution switch via GPIO51.

In case VBUS1 shall be actively controlled from the LPC4357 OEM Board, R190 and R198 must be soldered and pad 2-3 on SJ5 must be connected. Further, GPIO43/46/51 must not be used for other tasks in the design.

It is possible to force USB Host detection when using the USB OTG interface by inserting a jumper on JP16.

See picture below for locating relevant components. The table below lists signal connections.

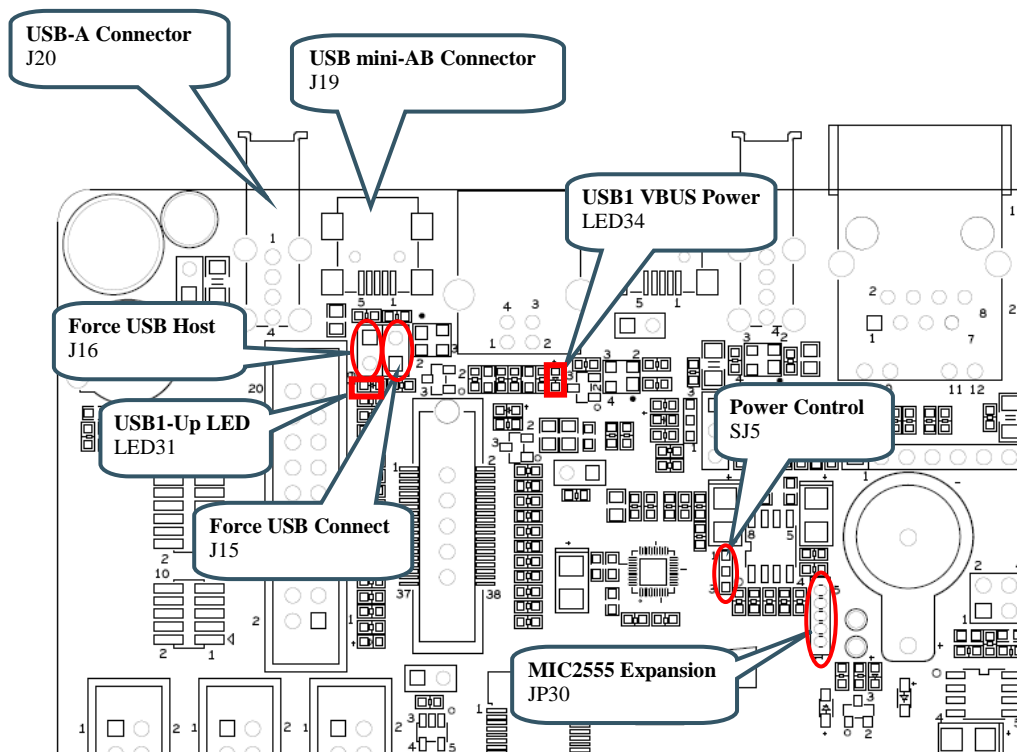

Figure 21 – USB Channel#1

Signals	LPC4357
USB1-DP	USB1-DP
USB1-DM	USB1-DM



GPIO42	P9_6
GPIO51	PB_2 (dual functions)
GPIO52	PB_1
GPIO53	PB_0
GPIO46	P8_3 normally not connected
GPIO43	PF_6 normally not connected

#### 4.20.1 USB Channel 1 as USB Host

When USB channel #1 is used as USB Host, 15Kohm pull-down resistors are needed on the USB data signals. These are activated inside the USB OTG chip (U31), and this has to be done via the I2C interface of GPIO52/GPIO53.

J20 is the connector to use when USB Host is used. In order to provide +5V to the external USB device connected to this connector (J20), channel A of U20 must be enabled. It is enabled by default since SJ5 is normally connected between pin 1-2. LED34 lights green when +5V is available on J20.

JP15 shall not be inserted. JP16 has no effect.

#### 4.20.2 USB Channel 1 as USB Device

When USB channel #1 is used as USB Device, a 1.5Kohm pull-up resistor is needed on the USB DP data signal. There are two methods to create this. JP15 is inserted and the pull-up resistor is always enabled. Alternatively, the pull-up resistor is activated inside the USB OTG chip (U31), and this has to be done via the I2C interface of GPIO52/GPIO53. In the latter case, JP15 shall not be inserted.

J19 is the connector to use when USB Device is used. Normally it should be a USB-B connector for creating a USB Device interface, but the mini-AB connector can also be used in this case. The status of VBUS can be read via U31.

JP16 shall not be inserted.

LED34 is has no meaning.

#### 4.20.3 USB Channel 1 as USB OTG

When USB channel #1 is used as USB OTG, pull-up and pull-down resistors are controlled via the USB OTG chip (U31), and this has to be done via the I2C interface of GPIO52/GPIO53. Note that some LCD signals interfere with the I2C signals to the USB OTG chip. In particular note that R163 is typically not mounted on the *OEM Base Board*.

J19 is the connector to use when USB OTG is used. VBUS is controlled via U31.

JP15 shall not be inserted.

LED34 is has no meaning.

JP16 can be inserted in order to force USB Host behavior on the interface (if the external device connected to J19 cannot pull the ID signal low).

## 4.21 SP12: USB Channel 2

This section describes the second USB interface on the board. This interface has a USB Host connector (USB-A), a USB OTG (USB mini-B) and a USB Device connector (USB-B). One of these interfaces can be used at a time, i.e., both cannot be used simultaneously. The software on the LPC4357 OEM Board is also different between the two interfaces.

This interface is connected to the USB0 interface on the LPC4357.

For USB Device operation; insert jumpers in position 1-2 in JP17/JP18/JP19. GPIO28 controls USB connect functionality and LED32 lights when the USB Device is connected. SJ4 has pads 1-2 shorted by default. LED33 is controlled by GPIO27 and signals USB-up state. GPIO54 is used for VBUS sensing.

For USB Host operation; insert jumpers in position 2-3 in JP17/JP18/JP19. USB Host power is controlled via distribution switch U20 (found in schematic page 11). Signal GPIO26 is active low and enables +5V on VBUS2. LED35 light whenever +5V is present on VBUS2. GPIO55 is connected to status feedback from the distribution switch. GPIO54 is used for VBUS sensing. 15Kohm pull-down resistors are always active.

See picture below for locating relevant components. The table below lists signal connections.

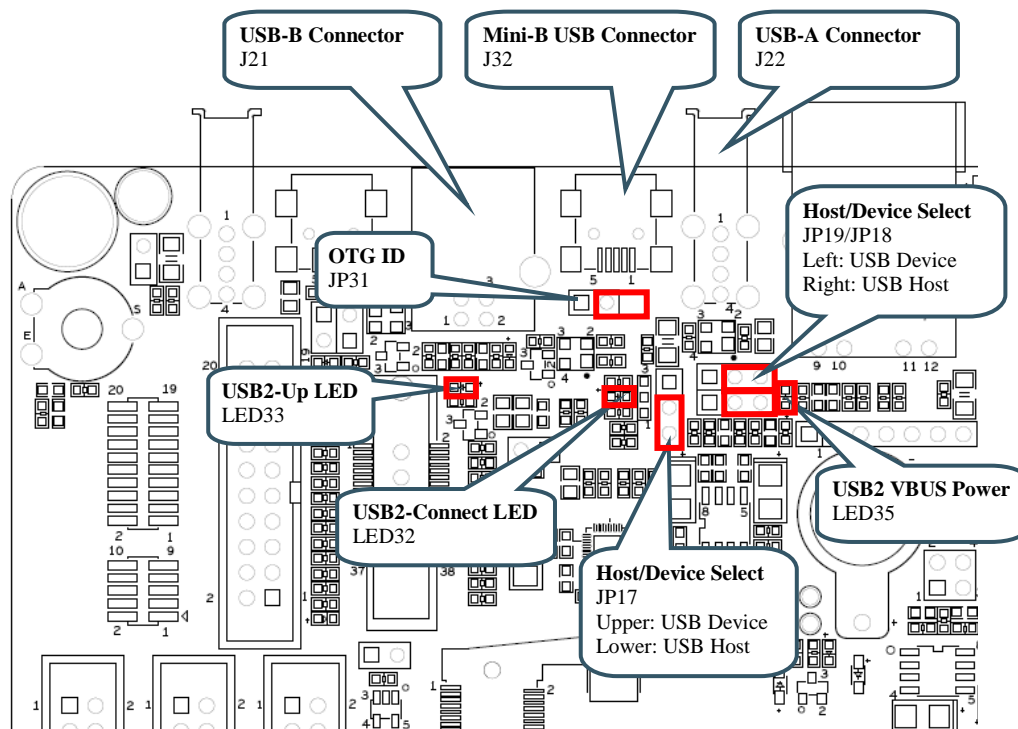

Figure 22 – USB Channel#2

Signals	LPC4357
USB2-DP	USB0-DP
USB2-DM	USB0-DM
GPIO27	P9_4
GPIO28	P9_5
GPIO54	USB0_VBUS
GPIO26	inverted P2_3, the signal has been inverted to be

	compatible with signal polarity of the OEM base board
GPIO55	P8_0
GPIO66	USB0_ID

#### 4.21.1 USB Channel 2 (USB0 on LPC4357) as USB Host

When USB channel #2 is used as USB Host, JP17/JP18/JP19 shall all be set in position 2-3.

J22 is the connector to use when USB Host is used. In order to provide +5V to the external USB device connected to this connector (J20), channel B of U20 must be enabled. VBUS2 is enabled by GPIO26 (active low). Over-current status back is provided via GPIO55. LED35 lights green when +5V is available on J22. The VBUS2 signal is also feed back to GPIO54.

JP31 has no effect.

LED33 can signal that an external USB device has been connected.

#### 4.21.2 USB Channel 2 (USB0 on LPC4357) as USB Device

When USB channel #2 is used as USB Device, JP17/JP18/JP19 shall all be set in position 1-2. Also a 1.5Kohm pull-up resistor is needed on the USB DP data signal. GPIO28 controls this. Alternatively, SJ4 pin 2-3 can be connected to always enable this pull-up resistor. LED32 lights when the pull-up resistor is enabled.

J21 is the connector to use when USB Device is used. This is a USB-B connector. The VBUS signal is also feed back to GPIO54.

LED35 is has no meaning.

JP31 has no effect.

#### 4.21.3 USB Channel 2 (USB0 on LPC4357) as USB OTG

The USB0 interface of the LPC4357 supports USB OTG directly.

JP17/JP18/JP19 shall all be set in position 2-3.

J32 is the connector to use when USB OTG is used. This is a mini-AB USB connector. The VBUS signal is also feed back to GPIO54.

LED35 is has no meaning.

JP31 shall be inserted.

### 4.22 SP13: UART-to-USB Bridge

There is a UART-to-USB bridge on the board. This is to simplify connection to a PC because serial ports are not so common any more, especially not on laptops. The USB port also offers the possibility to power the board. It is USART#0 that is connected to the USB channel. This UART is commonly used as the console channel for applications. Printf() output is for example typically directed to this UART channel.

The UART-to-USB bridge is based on the chip FT232RL from FTDI. A driver is typically needed to be installed on the PC side. The driver creates a virtual COM port on the PC that represents the UART channel. Any program on the PC can connect to this COM port for communication with the LPC4357 UART channel. There are two LEDs (Transmit – LED38 and Receive – LED37) that signal communication activity.

**It is NOT possible to download code in ISP-UART mode via this interface (like it is with other OEM boards). The jumpers in JP20 should NOT be inserted.** It was not possible to make pinning of the LPC4357 OEM board compatible with the OEM Base Boards to allow for automatic ISP invocation and usage of ISP-UART mode. Read section 5.4 for more information about how to download code to the LPC4357.

See picture below for locating relevant components. The table below lists signal connections.

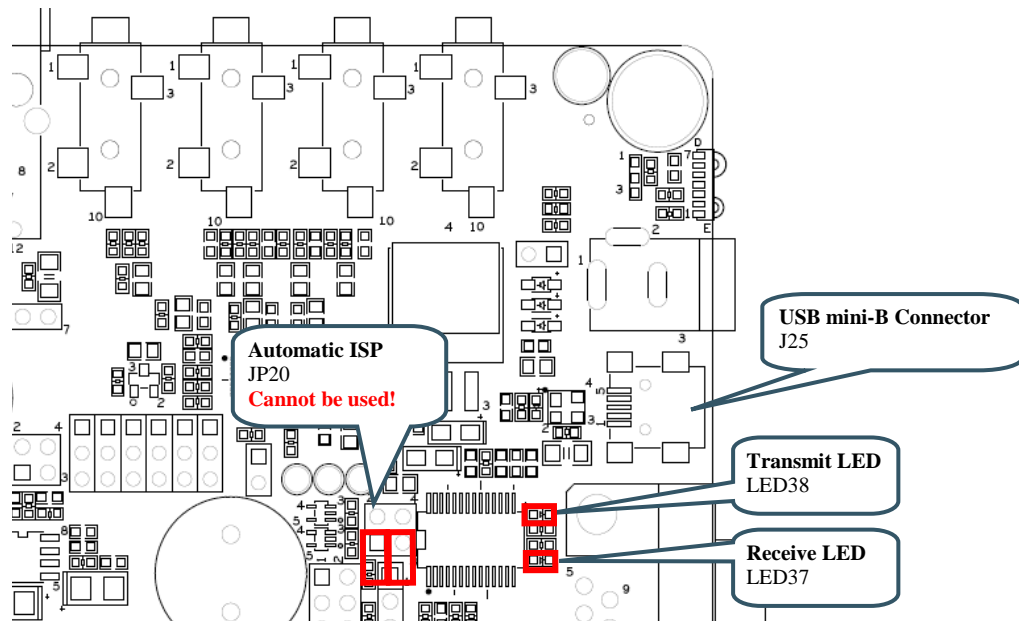

Figure 23 – UART-to-USB Bridge

Signals	LPC4357
GPIO16_TXD	PF_10, USART0 is used
GPIO17_RXD	PF_11, USART0 is used

### 4.23 SP13: Power Supply

The power supply on the board is straight forward. There are three powering sources:

1. +5V DC via 2.1mm power jack (J24). Center pin positive. There is also an alternative connector (J23) for this powering option.
2. USB powering via the USB-to-UART Bridge connector (J25).
3. +5V DC power from the PoE (Power-over-Ethernet) connector (J12).

In all cases, a stable +5V DC voltage powers the board. Current consumption depends on USB Host usage. If USB Host is not used (or used with very low external current consumption), a 1 Amp power supply (5W) is all what is needed. If USB Host is used with high external current consumption a 2-2.5 Amp power supply (10-12.5W) is needed.

The second powering option, via the USB-to-UART connector will work in most cases. Note however that not all PC:s and laptops can provide this amount of current. An external USB Hub can be used in that case or an external power supply.

U21 is a 1.5A +3.3V linear regulator. LED36 signals presence of regulated +3.3V. Three voltage measurement pads exist for verifying correct voltage levels on the board. See picture below for locating relevant components. The table below lists signal connections.

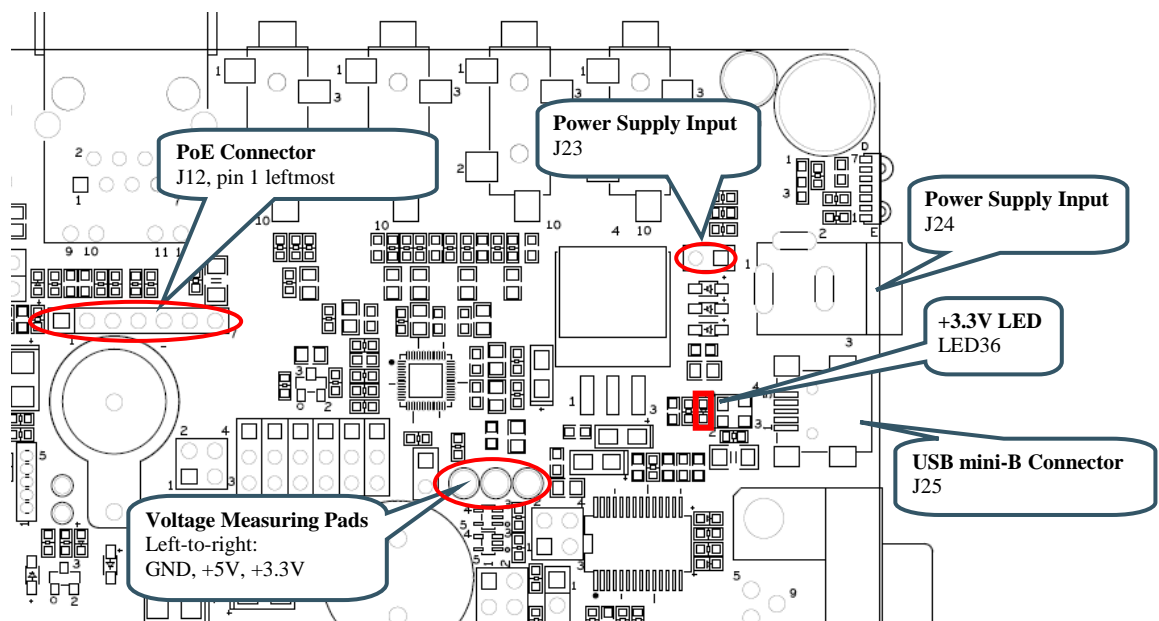

Figure 24 – Power Supply

### 4.24 SP14: LCD Expansion Interface

The board contains a buffered LCD expansion interface via a 50 pos IDC connector. The expansion interface also includes UART (see UART multiplexing), I2C and SPI interfaces. These additional interfaces are for identifying external displays (via configuration I2C-E2PROM) as well as touch screen controllers. An external LCD pixel clock can also be supplied via the expansion connector.

The LCD expansion connector carries 18 data bits per pixel by default. (6 per RGB color). The LPC4350 LCD controller can produce 24 data bits per pixel and it is possible to output all these signals on the LCD expansion connector. The trade-off is that the UART and I2C serial interfaces have to be removed. Via SJ6-SJ11 it is possible to select what signals to make available on the LCD expansion connector. By default pad 1-2 are connected on SJ6-SJ11.

On rev B of the OEM base board, JP34 has been added to support the LPC4357 OEM board. JP34 shall be in position 2-3 to route signal LCD\_VD3 properly (to where LCD\_VD18 otherwise is). The reason for this is for backward compatibility with previous OEM board designs. **Note that the default setting for JP34 is 1-2 and not 2-3, which it should be for LPC4357.**

For performance reasons (on the LPC4357), a system with 16-bit color information per pixel is typically what is implemented.

See picture below for locating relevant components. The table below lists signal connections.

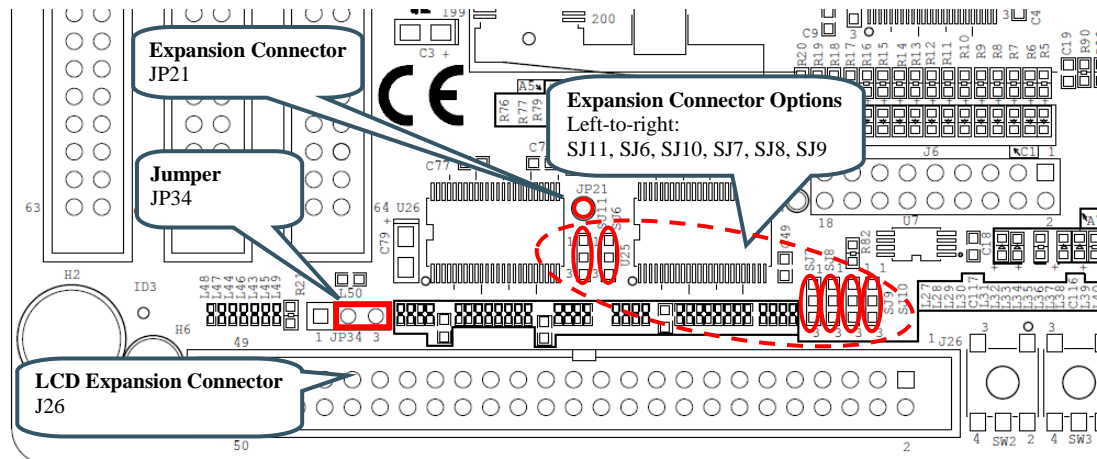

Figure 25 – LCD Expansion Interface

Signals	LPC4357
I2C-SDA	I2C-SDA
I2C-SCL	I2C-SCL
LCD_UART_RXD	P2_4 via multiplexor, USART#3 is used
LCD_UART_TXD	P9_3 via multiplexor, USART#3 is used
BSPI_SCK	PF_0 via buffer
BSPI_MOSI	PF_3 via buffer
GPIO31	PF_2
GPIO30	PF_1
GPIO33	P4_0
GPIO34	PE_15
GPIO70	P8_1
GPIO42	P9_6

#### 4.25 SP15: I2S Audio Codec

The board contains an I2S audio codec based on UDA1380 from NXP. The codec is controlled via I2C and audio data is transferred over the I2S bus.

The OEM Base Board supports different OEM Boards and the I2S signals can be located at two different groups of signals from the OEM Board. Jumper JP22-JP27 selects which group of signals to connect to the I2S interface of the UDA1380. For LPC4357 OEM Board, set all jumpers in lower position (see picture below).

The audio codec provides a mono microphone input, a stereo line input, a stereo line output and a stereo headphone output. The board also has an on-board speaker. The right line output can be used to drive the speaker. The analog output from the LPC4357 as well (signal GPIO40).

See picture below for locating relevant components. The table below lists signal connections.

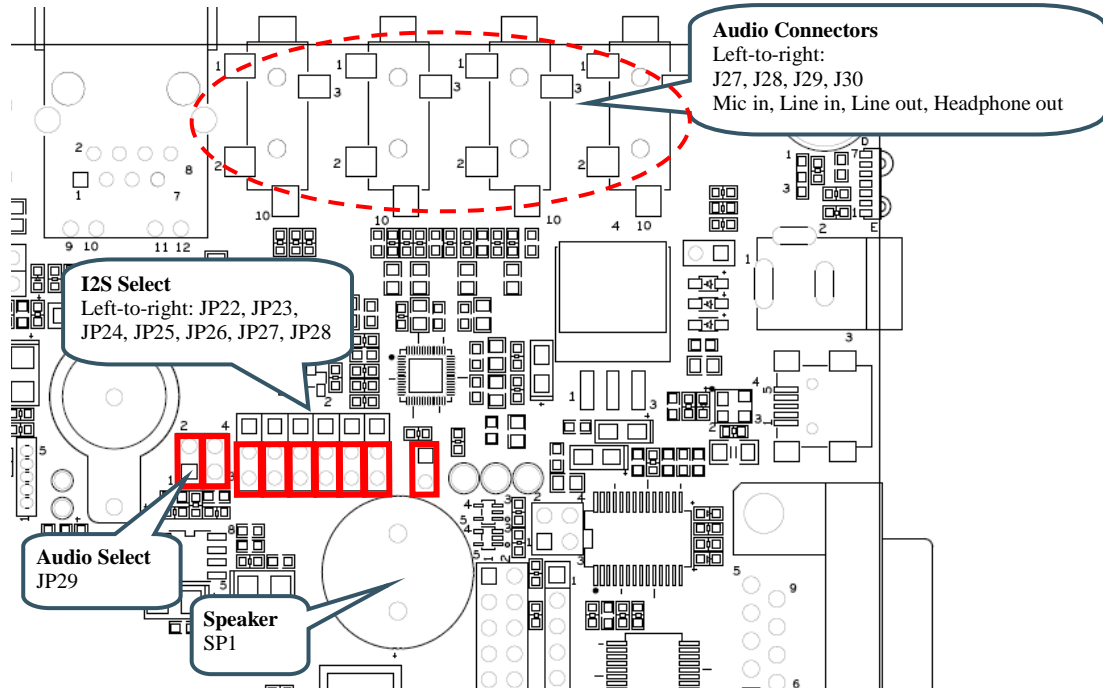

Figure 26 – I2S Audio Codec Interface

Signals	LPC4357
I2C-SDA	I2C-SDA
I2C-SCL	I2C-SCL
GPIO40	ADC0/DAC
GPIO56	P3_0
GPIO57	PC_12
GPIO58	PC_13
GPIO59	P6_0
GPIO60	P6_1
GPIO61	P6_2
GPIO68	CLK2_OUT

## 4.26 Default Jumpers Positions

Figure 27 illustrates the default jumper positions as mounted when the board is delivered from Embedded Artists. Default jumpers are marked with red color.

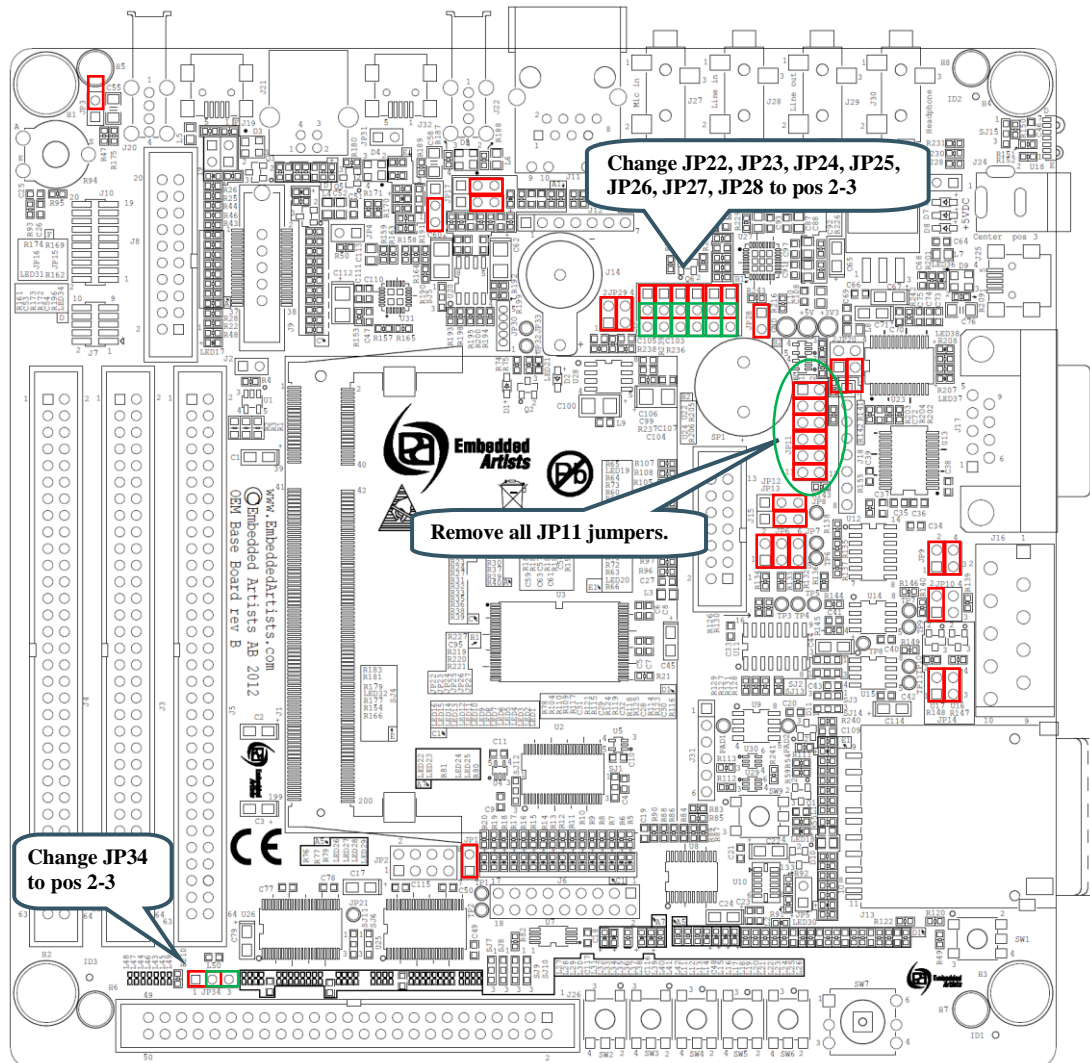

Figure 27 – OEM Base Board Default Jumper Positions

Note that the default position for the six I2S jumpers is not what is needed for the LPC4357 OEM board. Also, JP34 is in wrong position. Before working with I2S audio and the LCD interface change the jumper settings. Remove all JP11 jumpers. Jumpers needed to change are marked with green – this is the position they should have.

Some signals are used on different interfaces that cannot be active simultaneous. See table in next section for information about pin usage.



## 4.27 Usage of CPU Pins

Almost all pins of the LPC4357 are directly available on the expansion connectors. Only in a few cases are pins used for dedicated functionality like Ethernet interface and chip select signals. Such pins are not available on the expansion connector. The table below lists all pins and their possible restrictions.

<b>OEM Base Board signal name</b>	<b>LPC4357 Pin (OEM Board signal name)</b>	<b>Usage</b>
GPIO0	P7_7	LCDPWR signal to LCD expansion connector.
GPIO1	P7_0	LCDLE signal to LCD expansion connector.
GPIO2	P4_7	LCDDCLK signal to LCD expansion connector. Connects to trace connector but not relevant for LPC4357.
GPIO3	P4_5	LCDFP signal to LCD expansion connector. Connects to trace connector but not relevant for LPC4357.
GPIO4	P4_6	LCDENAB signal to LCD expansion connector. Connects to trace connector but not relevant for LPC4357.
GPIO5	P7_6	LCDLP signal to LCD expansion connector. Connects to trace connector but not relevant for LPC4357.
GPIO6	P8_7	LCD databit 4. Connects to trace connector but not relevant for LPC4357.
GPIO7	P8_6	LCD databit 5.
GPIO8	P8_5	LCD databit 6.
GPIO9	P8_4	LCD databit 7.
GPIO10	ISP_EN	Connected to push-button (for enabling bootloader during reset). Also connects to LED (active low).  Connects to USB-to-serial bridge (for automatic ISP functionality)
GPIO11	PF_4	LCD clock input, an external clock signal can be feed to this pin.
GPIO12	P7_2	LCD databit 18
GPIO13	P7_1	LCD databit 19
GPIO14	P3_1	Connects to RD1 for CAN channel #1, can also connect to IrDA transceiver.  IrDA functionality is not supported by LPC4357 OEM board pinning.
GPIO15	P3_2	Connects to TD1 for CAN channel #1, can also connect to IrDA transceiver.  IrDA functionality is not supported by LPC4357 OEM board pinning.
GPIO16	PF_10	Connects to USB-to-serial bridge (TxD on USART #0).
GPIO17	PF_11	Connects to USB-to-serial bridge (RxD on USART #0).
GPIO18	P4_1	LCD databit 0, can also be connected to RD2 for CAN channel

		#2. CAN interface not supported by LPC4357 OEM board pinning.
GPIO19	P4_4	LCD databit 1, can also be connected to TD2 for CAN channel #2 CAN interface not supported by LPC4357 OEM board pinning.
GPIO20	P7_5	LCD databit 8
GPIO21	P4_8	LCD databit 9
GPIO22	P7_4	LCD databit 16
GPIO23	P7_3	LCD databit 17
GPIO24	P9_3	Connects to UART multiplexing (TxD); further to LCD expansion connector, serial expansion connector, RF module, RS232 and RS422/485.
GPIO25	P2_4	Connects to UART multiplexing (RxD); further to LCD expansion connector, serial expansion connector, RF module, RS232 and RS422/485.
GPIO26	inverted P2_3	Connects to USB2 VBUS power enable.
GPIO27	P9_4	Connects to USB2-up LED (active low).
GPIO28	P9_5	Connects to USB2-connect functionality (for USB device operation).
GPIO29	PF_0	SPI-SCK. Connects to LCD expansion connector via buffer. Connects to serial expansion connector.
GPIO30	PF_1	SPI-SSEL. Connects to LCD expansion connector.
GPIO31	PF_2	SPI-MISO. Connects to LCD expansion connector. Connects to serial expansion connector.
GPIO32	PF_3	SPI-MOSI. Connects to LCD expansion connector via buffer. Connects to serial expansion connector.
GPIO33	P4_0	Connects to LCD expansion connector (GPIO function).
GPIO34	PE_15	Connects to LCD expansion connector (GPIO function, touch controller spi-sel).
GPIO35	ADC5	No special usage on <i>OEM Base Board</i> .
GPIO36	ADC4	No special usage on <i>OEM Base Board</i> .
GPIO37	ADC1	Connects to serial expansion connector.
GPIO38	ADC2	Connects to serial expansion connector.
GPIO39	ADC3	Connects to trimming potentiometer.
GPIO40	ADC0/DAC	Connects to speaker output on AOUT signal.
I2C-SDA	I2C-SDA	I2C-SDA, connects to PCA9532, E2PROM, LM74, 3-axis Accelerometer, audio codec, serial expansion connector, lcd expansion connector.
I2C-SCL	I2C-SCL	I2C-SCL, connects to PCA9532, E2PROM, LM74, 3-axis Accelerometer, audio codec, serial expansion connector, lcd

		expansion connector.
USB1-DP/DM	USB1-DP/DM	Connects to USB Host/OTG interface
USB2-DP/DM	USB0-DP/DM	Connects to USB Host/Device interface
MCICLK	PF_5	Connects to MCICLK on SD/MMC connector Note that LPC4357 OEM Board pinning does not support the MCI interface. Use uSD/transflash memory card interface on LPC4357 OEM board instead.
MCICMD	PC_11	Connects to MCICMD on SD/MMC connector Note that LPC4357 OEM Board pinning does not support the MCI interface. Use uSD/transflash memory card interface on LPC4357 OEM board instead.
MCIPWR	PC_3	Connects to MCIPWR on SD/MMC connector Note that LPC4357 OEM Board pinning does not support the MCI interface. Use uSD/transflash memory card interface on LPC4357 OEM board instead.
MCIDAT0	PD_4	Connects to MCIDAT0 on SD/MMC connector Note that LPC4357 OEM Board pinning does not support the MCI interface. Use uSD/transflash memory card interface on LPC4357 OEM board instead.
MCIDAT1	PF_7	Connects to MCIDAT1 on SD/MMC connector Note that LPC4357 OEM Board pinning does not support the MCI interface. Use uSD/transflash memory card interface on LPC4357 OEM board instead.
MCIDAT2	PC_14	Connects to MCIDAT2 on SD/MMC connector Note that LPC4357 OEM Board pinning does not support the MCI interface. Use uSD/transflash memory card interface on LPC4357 OEM board instead.
MCIDAT3	P2_5	Connects to MCIDAT3 on SD/MMC connector Note that LPC4357 OEM Board pinning does not support the MCI interface. Use uSD/transflash memory card interface on LPC4357 OEM board instead.
GPIO41	P8_8	No special usage on <i>OEM Base Board</i> .
GPIO42	P9_6	Connects to LCD expansion connector (backlight control). Connects to USB1-up LED (active low). Connects to serial expansion connector.
GPIO43	PF_6	Connects to RS422/485 transmit/receive control. Can optionally be connected to USB1 VBUS power enable.
GPIO44	P4_10	LCD databit 10
GPIO45	P4_9	LCD databit 11
GPIO46	P8_3	LCD databit 12 Can optionally be connected to USB1 VBUS feedback.
GPIO47	PB_6	LCD databit 13

GPIO48	PB_5	LCD databit 14
GPIO49	PB_4	LCD databit 15
GPIO50	PB_3	LCD databit 20
GPIO51	PB_2	LCD databit 21. Also connected to USB OTG transceiver, interrupt signal. Can optionally be connected to USB1 VBUS power switch over-current flag.
GPIO52	PB_1	LCD databit 22, can also be connected to USB OTG transceiver
GPIO53	PB_0	LCD databit 23, can also be connected to USB OTG transceiver
GPIO54	USB0_VBUS	Connects to USB2 VBUS signal.
GPIO55	P8_0	Connects to USB2 VBUS power switch over-current flag.
GPIO56	P3_0	Can be connected to I2S audio codec BCKI (I2S_TX_SCK)
GPIO57	PC_12	Can be connected to I2S audio codec BCKI (I2S_TX_SDA)
GPIO58	PC_13	Can be connected to I2S audio codec BCKI (I2S_TX_WS)
GPIO59	P6_0	Can be connected to I2S audio codec BCKI (I2S_RX_SCK)
GPIO60	P6_1	Can be connected to I2S audio codec BCKI (I2S_RX_WS)
GPIO61	P6_2	Can be connected to I2S audio codec BCKI (I2S_RX_SDA)
GPIO62	WAKEUP3	No special usage on <i>OEM Base Board</i> .
GPIO63	WAKEUP2	No special usage on <i>OEM Base Board</i> .
GPIO64	WAKEUP1	No special usage on <i>OEM Base Board</i> .
GPIO65	WAKEUP0	No special usage on <i>OEM Base Board</i> .
GPIO66	USB0_ID	Can be connected to USB2 OTG interface, id-pin
GPIO67	SAMPLE	No special usage on <i>OEM Base Board</i> .
GPIO68	CLK2_OUT	Can be connected to I2S audio codec SYSCLK.
GPIO69	P9_2	Can be used as chip select for 16-bit register on external memory bus, but not for the LPC4357.  Can be used as enable signal for IrDA transceiver (active low).
GPIO70	P8_1	Connects to LCD expansion connector (interrupt signal from touch screen controller).
GPIO71	P8_2	Can be connected to Ethernet PHY interrupt output
GPIO72	PC_2	Can be connected to NAND FLASH busy output. Connects to serial expansion connector.
GPIO73	PA_1	Connects to joystick switch
GPIO74	PA_2	Connects to joystick switch
GPIO75	PA_3	Connects to joystick switch
GPIO76	P9_0	Connects to joystick switch
GPIO77	P9_1	Connects to joystick switch
GPIO78	PF_8	No special usage on <i>OEM Base Board</i> .

GPIO79	PF_9	No special usage on <i>OEM Base Board</i> .
GPIO80	P4_3	LCD databit 2.
GPIO81	P4_2	LCD databit 3
BD0-BD15	Buffered signals	Occupied for 16-bit databus versions. Connects to parallel NOR flash and 16-bit register.
BD16-DB31	Buffered signals	Also occupied for 32-bit databus versions, which is what the LPC4357 OEM board has.  No special usage on <i>OEM Base Board</i> , but some pins can be connected to RS232 interface. Make sure all jumpers in JP11 are removed.
BA0-BA23	Buffered signals	The address bus, buffered signals from OEM Board. Connects to parallel NOR flash and 16-bit register.
BOE	Buffered P1_3	OE, buffered signal from cpu board . Connects to parallel NOR flash.
BWE	Buffered P1_6	WE, buffered signal from cpu board. Connects to parallel NOR flash and 16-bit register.
BBLS0	Buffered P1_4	BLS0 controls lower 8 bits of external memory databus (16-bit parallel register). Connects to 16-bit register.
BBLS1	Buffered P6_6	BLS1 controls upper 8 bits of external memory databus (16-bit parallel register). Connects to 16-bit register.
BRAS-BCS0- <b>BBS2</b>	Buffered PD_13	BLS2 controls bit 16-23 of external memory databus.
BCAS-BCS1- <b>BBS3</b>	Buffered PD_10	BLS3 controls bit 24-31 of external memory databus.
BCSY	Buffered P1_5	CS0, chip select for parallel NOR flash.
BCSX	Buffered PD_12	CS2, chip select for parallel 16-bit register.
DBUS_EN- <b>BCS3</b>	Buffered PD_11	CS3, chip select.  No special usage on <i>OEM Base Board</i> .
VBAT	VBAT	Coin cell battery can connect to vbat signal
ALARM	ALARM	Connected to alarm-LED (active high)
VREF	ADC6	LPC4357 signal connected has nothing to do with VREF. ADC6 placed here to use otherwise unused pins.  Remove resistor R93 on OEM Base board in order to use ADC6.
VDDA, VSSA	VDDA, VSSA	Used to generate reference voltage for trimpot (analog inputs)
SWD/JTAG signals	SWD/JTAG signals	Connected to SWD/JTAG connectors  Note that the LPC4357 MCU is sensitive to ESD on the JTAG port. Observe extra care around this.  <b><i>Make sure the ground of the JTAG interface is connected to</i></b>

		<b><i>the OEM Base Board ground before even connecting the JTAG interface. Never have the OEM Board unpowered while the JTAG pod is powered.</i></b>
RESET_IN	RESET	Connects to RESET push-button and USB-to-serial bridge (for automatic ISP functionality)
RESET_OUT	RESET	Connects to RESET LED indicator. Used to reset PCA9532, UDA1380, FT232RL, MIC2555, RF module and LCD expansion connector.

## 5 Getting Started

This chapter contains information about how to get acquainted with the *LPC4357 Developer's Kit*. **Please read this section first before you start using the board - it will be well spent time!**

### 5.1 Powering

The board can normally be powered from a PC/laptop via the included USB cable (mini-B to A cable). This is done via the USB-to-UART connector and will work in most cases. Note however that not all PC/laptops can provide the needed current. An external USB hub can be used in this case or an external power supply.

A separate power supply is always needed in stand-alone situations or when running USB Host application (when powering external USB devices). If USB Host is not used (or used with very low external current consumption), a 5VDC/1 Amp power supply (5W) is all what is needed. If USB Host is used with high external current consumption a 5VDC/2-2.5 Amp power supply (10-12.5W) is needed. A 2.1mm standard power plug is used to interface the board. Center pin is positive.

See *Figure 28* below for locating the USB connector and/or the 2.1mm power connector.

It is possible to have both the USB cable and external powering connected to the board at the same time.

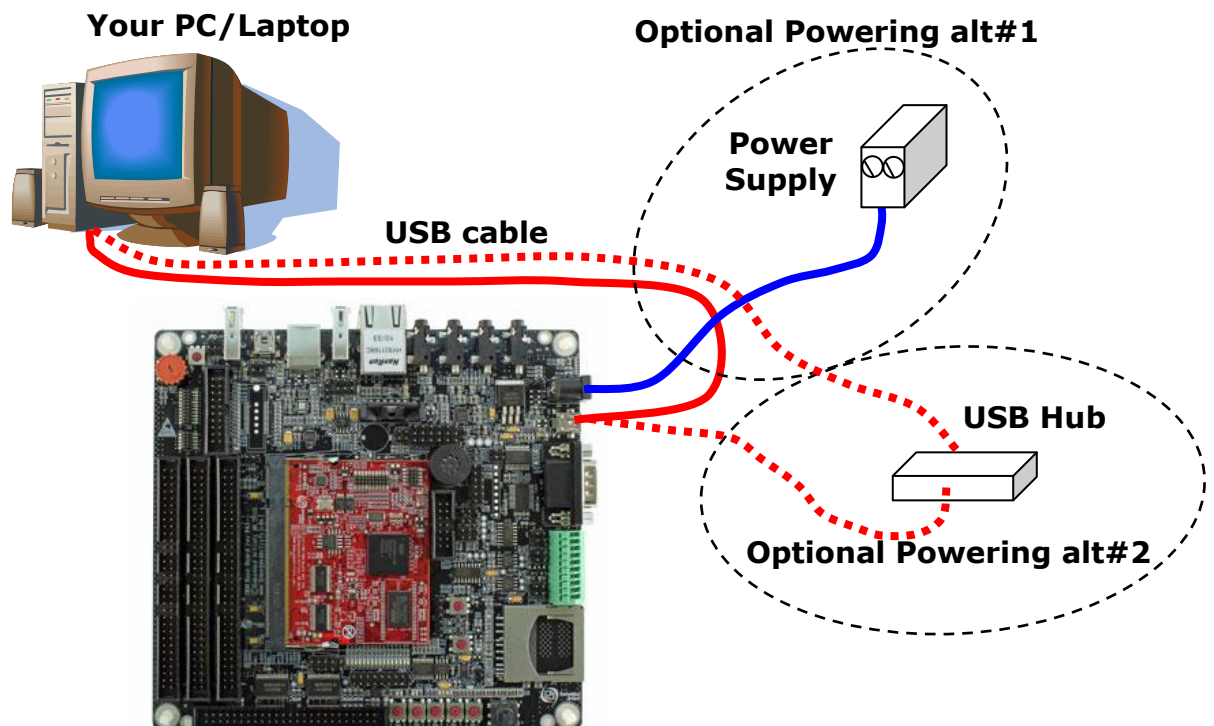

Figure 28 – Powering of OEM Base Board

### 5.2 Demo Application

The LPC4357 Developer's Kit comes pre-loaded with a demo application. If the demo application is missing or over-written by another application, follow the guidelines for how to download a program to the LPC4357, see section 5.4 . The source code and pre-compiled hex-file is available on the support site.

The demo application demonstrates some features of the LPC4357 Developer's Kit:

- The accelerometer and memory mapped register; the row of LEDs (LED16 to LED1) are controlled by tilting the board. Note that this demo does not function after March 2017 (since the accelerometer is obsolete and no longer mounted).
- Buttons and PCA9532 port expander; there is a running-light pattern on the 8 LEDs controlled by the I<sup>2</sup>C port expander. By pressing the push-buttons (also on the I<sup>2</sup>C port expander) the pattern can be changed.
- Joystick and GPIO; the 5-key joystick can also control the running-lights pattern. UP-key increases the speed, CENTER-key returns it to normal and DOWN-key decreases the speed. LEFT-key changes to the previous pattern for the running lights and RIGHT-key changes to the next pattern.
- Speaker and DAC; the melody played at startup demonstrates the use of DAC to output a short sound clip.
- UART and USB-to-UART bridge; a message is printed on the UART. It will look like this:

```
*****
*
* Demo Application for the LPC4357 OEM Board...
* (C) Embedded Artists AB 2012
*
*
* Thank you for buying Embedded Artists'
* LPC4357 Developer's Kit
*
* ... and congratulations on your choice
* of microcontroller!
*
*****
Version: 1.0, (build October 24 2012)
```

- LCD controller; the program will detect if a display (one of Embedded Artists' LCD boards) is connected on the LCD Expansion Connector and display an image on it, like below.



Figure 29 – Demo Application Image



### 5.3 Installing USB Driver

The *OEM Base Board* contains an USB-to-UART bridge chip (FT232R from FTDI) that connects UART channel #0 on the LPC4357 to a virtual COM port on the PC/laptop (via USB). This UART channel is typically used as the console channel for applications. Printf() output can for example be directed to this UART channel.

A USB driver must be installed on the PC/laptop in order for the virtual COM port to be created. See FTDI's installation guides for details how to install the driver for different operating systems:

<http://www.ftdichip.com/Support/Documents/InstallGuides.htm>

### 5.4 Program Download

This section describes some basic methods for downloading application code to the LPC4357. Note that this section does not describe how to create the application code (write the program and compile it). It is assumed that a binary file exist that represent the application program. This file is often also called hex-file, which is a file format that Intel created a long time ago. It can also be a pure binary file (which is typically called a bin-file).

There are four basic methods for program download (the top two methods are the recommended):

- **ISP over USB**

ISP is short for In-System Programming. The LPC4357 contains a bootloader in ROM that can be enabled by pulling pin P2\_7 low during reset (pulling signal ISP\_EN low will pull P2\_7 low). With proper bootmode setting (USB0 booting selected), the application can then be downloaded over USB #0. The DFU class is used to download the application, also called the 'boot image'.

An application is needed on the PC for downloading the application code. NXP provides this application called DFUsec, from <http://www.lpcware.com/content/project/dfu-download-programming-utility-and-security-lpcdfusec-tool/>.

Using this method, it is possible to load the application into (internal) SRAM or to (internal) flash memory or (external) spifi flash.

Details about this method are found in sub-section below.

**Note that the USB1 bootmode is not supported on the OEM Base Board.**

- **SWD/JTAG**

There are many different SWD/JTAG interfaces on the market. NXP has created LPC-LINK. Keil has ULINK. IAR/Segger has JLINK. Code Red has Red Probe, etc. There is also OpenOCD, which is an open source project. Consult the respective manual for the SWD/JTAG interface used to get instructions how to download a hex/binary file via SWD/JTAG.

Using this method, the application can be downloaded to (internal) SRAM, to (internal) flash memory, to (external) NOR flash or (external) spifi flash. Note that the debugger needs special download functionality in order to download to flash memories (internal or external). Check the supported functions in the program development environment/IDE that is used.

SWD/JTAG

**Note that the LPC4357 MCU is sensitive to ESD on the JTAG port. Observe extra care around this. Make sure the ground of the JTAG interface is connected to the OEM Base Board ground before even connecting the JTAG interface. Never have the OEM Board unpowered while the JTAG pod is powered.**

- **ISP over UART**

ISP is short for In-System Programming. The LPC4357 contains a bootloader in ROM that can be enabled by pulling pin P2\_7 low during reset (pulling signal ISP\_EN low will pull P2\_7 low). With proper bootmode setting (USART#0/#3 booting selected), the application can then be downloaded over USART#0 or #3. An application is needed on the PC for downloading the application code, for example Flash Magic (<http://www.flashmagictool.com/>).

**Note that the LPC4357 OEM board does not support ISP over USART booting due to**

pinning conflicts. It was not possible to place the used pins for USART communication on the pins to make it compatible with other OEM boards and the OEM Base Board. Note however that the pins for USART#0, P2\_0 and P2\_1, are available as special test points on the pcb, TP4 and TP5, respectively. The pins for USART #3, P2\_3 and P2\_4 are also available as special test points on the pcb, TP6 and TP7, respectively. TP4/TP5 are found in the upper right corner of the pcb and TP6/TP7 are found in the upper left corner of the pcb.

#### - IAP over Ethernet or USB

IAP is short for In-Application Programming. In this case, the LPC4357 must have a small bootloader installed that allow application code to be downloaded over Ethernet, USB or some other communication channel. The bootloader must be created by the user and is typically specific for the application. This method is not supported by any sample applications from Embedded Artists.

Embedded Artists support site contains sample applications for the LPC4357 Developer's Kit. Source code and pre-compiled binary images (hex-files) can be downloaded from there.

#### 5.4.1 ISP over USB Program Download

When using ISP over USB, both USB interfaces can be used. Set the active USB interface via the bootmode sliders to USB0. See sections 3.3 and LPC4357 User's Manual for details. Use USB connector J21 (USB-B connector) or J32 (USB mini-B connector) as shown in Figure 30. Note that jumpers JP17-JP19 must be in different positions depending on which connector that is used.

**Note that the OEM Board can be configured for either USB0 or USB1 bootmode but the OEM Base Board only support USB0 boot mode.**

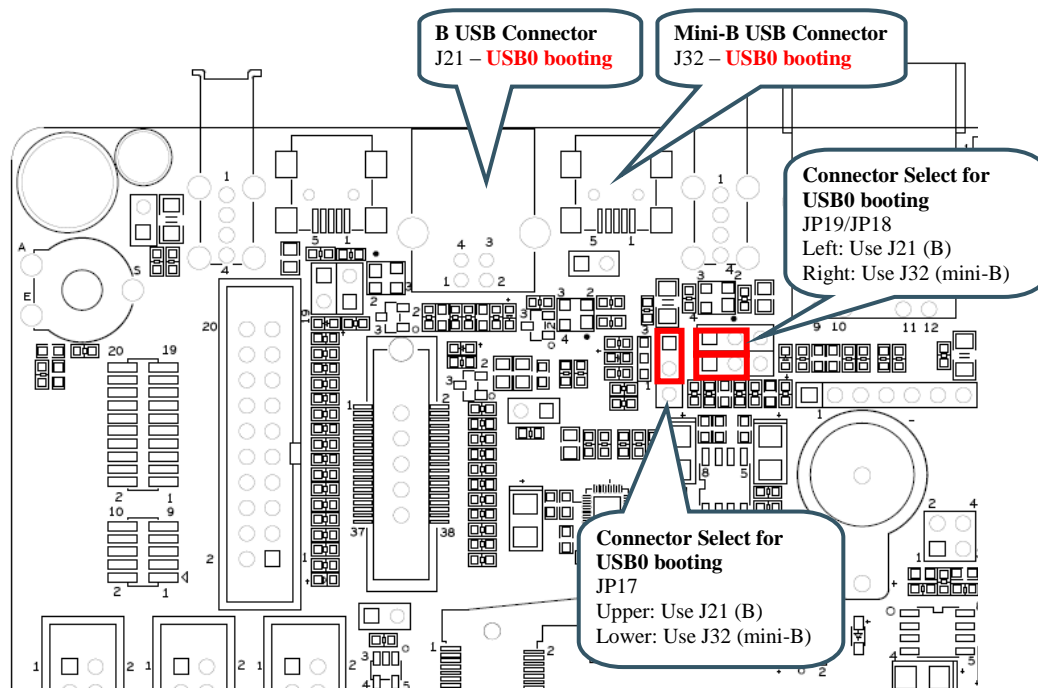

Figure 30 – Booting via USB Channel #0 or #1

Three situations will be described below. In all cases, the DFUsec application from NXP must be downloaded and installed. Select latest version (currently v1.11). Download it from here: <http://www.lpcware.com/content/project/dfu-download-programming-utility-and-security-lpcdfusec-tool/>, or go to <http://www.lpcware.com/> and search for “lpc\_dfusec”.

#### 1) Download to internal SRAM (code size $\leq 32$ Kbyte)

Make sure that the application fit within 32Kb and setup linking to place it in SRAM starting at address 0x10000000.

- A \*.bin file must be created. In Keil uVision this is done by adding the following user command:  

```
fromelf --bin -o "$L@L.bin" "$L@L.axf"
```

 See the project files in the sample applications for how it is added to the compile process.
- Settings in lpc\_dfusec  
 Use the "HDR/RAW modes" tab. Point to the binary file and make sure that the "Auto append header..." checkbox is ticked.

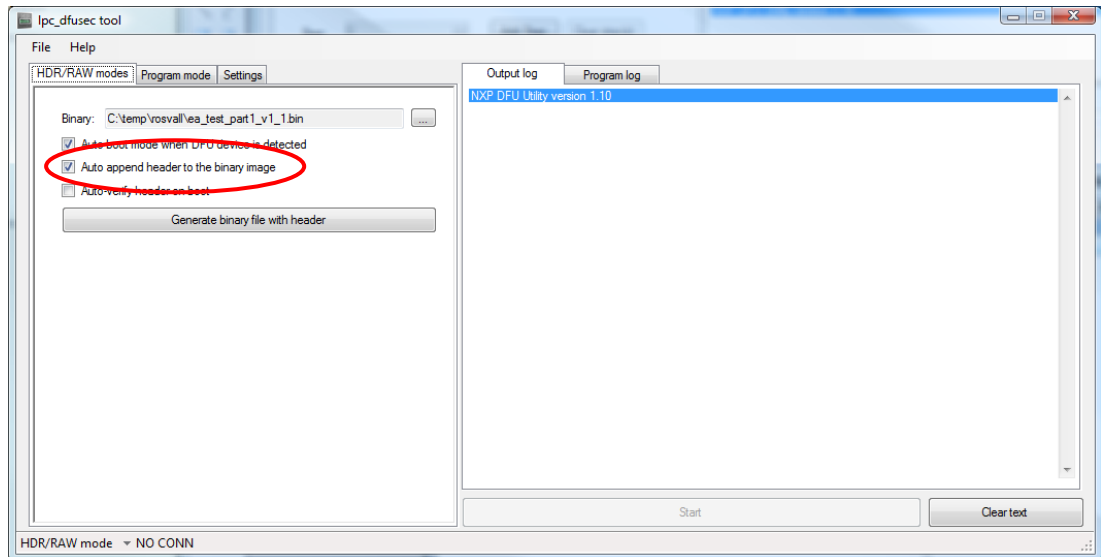

Figure 31 – LPC DFU Download Options

## 2) Download to internal FLASH (code size ≤512Kbyte)

Make sure that the application fit within 512Kbyte and setup linking to place it in FLASH starting at address 0x1A000000.

- A header must be added to the binary that represents that application. In Keil uVision this is done by adding the following user command:

```
$K\ARM\BIN\ELFDWT.EXE !L BASEADDRESS(0x1A000000)
```

See the project files in the sample applications for how it is added to the compile process.

- A \*.bin file must be created. In Keil uVision this is done by adding the following user command:

```
fromelf --bin -o "$L@L.bin" "$L@L.axf"
```

See the project files in the sample applications for how it is added to the compile process.

- Settings in lpc\_dfusec  
 See Figure 32 for details of the description below.
  1. Use the "Program Mode" tab.
  2. Only "Step 0" is used.
  3. For "Algo", select the file programming\_algos\iram\_dfu\_util\_any.bin.hdr

4. For "File", select the **\*.bin** file that has been generated to be downloaded
5. For "Address", enter 0x1A000000
6. For "Size", enter 0x00080000
7. The "Param" field is not used so leave it as default
8. Tick the "Erase region before programming" checkbox
9. Tick the "Compute/Insert checksum..." checkbox

Start the board in DFU mode and wait for the "NO\_CONN" status in the lower left corner to change into "HIGH SPEED USB". Then press the "Start" button to download. The program should then be flashed and started automatically.

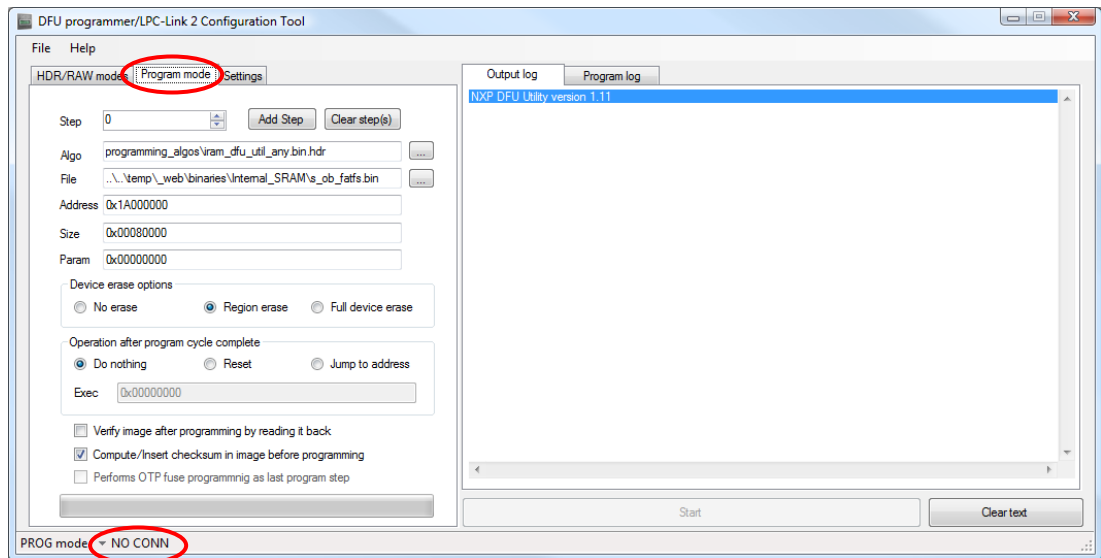

Figure 32 – LPC DFU Download Program Mode Options

### 3) Download to internal FLASH (code size >512Kbyte)

Same as option 2) above, but instead of a single **\*.bin** file generated, a folder with ER\_IROM1 and ER\_IROM2 files in it will be generated.

1. Follow the same steps as option 2) above when setting up DFUsec. Select the ER\_IROM1 file to be downloaded in "step 0".
2. Click "Add Step" (to configure step 1)
3. For "Algo", select the file programming\_algos\iram\_dfu\_util\_any.bin.hdr
4. For "File", select the ER\_IROM2 file that has been generated to be downloaded
5. For "Address", enter 0x1B000000
6. For "Size", enter 0x00080000
7. The "Param" field is not used so leave it as default
8. Tick the "Erase region before programming" checkbox
9. Tick the "Compute/Insert checksum..." checkbox

Start the board in DFU mode and wait for the "NO\_CONN" status in the lower left corner to change into "HIGH SPEED USB". Then press the "Start" button to download. The program should then be flashed and started automatically.

## 5.5 Handling SO-DIMM Boards

See picture below for instructions about how to mount/remove the *LPC4357 OEM Board*.

To install the *OEM Board*, align it to the socket (1). Push the board gently, and with even force between the board edges, fully into the socket (2). Then push the board down in a rotating move (3) until it snaps into place (4). The *OEM Board* shall lie flat and parallel to the base board.

To remove the *OEM Board*, spread the two arms of the SO-DIMM socket apart slightly. The board will pop up (5). Gently rise the board in a rotating move (6) and then extract the board from the socket (7). Apply even force between board edges when removing so that the board is removed parallel to the locking arms.

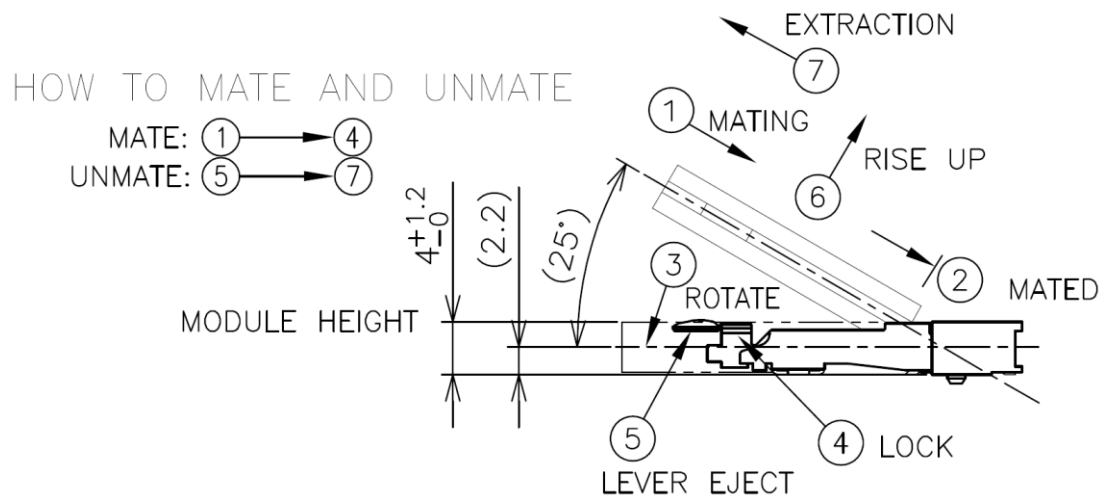

Figure 33 – Instructions how to Mount/Remove the LPC4357 OEM Board

Do not forget to follow standard ESD precaution routines when mounting/removing the *OEM Board*. Most signals exposed on the 200 edge contact fingers on the SO-DIMM board are unprotected. Maintain the same electrical potential of the *OEM Board* (to be mounted) and the base board. Do not touch the *OEM Board* edge connectors. Handle the *OEM Board* only by the three other edges. Also, do not touch the components on the board.

## 5.6 Things to Note

This section lists things to note when using the *LPC4357 OEM Board* and the *OEM Base Board*.

### 5.6.1 Low Speaker Audio Volume

The speaker audio volume can be low on some *OEM Base Board*, rev C boards produced in Q1-2018. The reason for this is variations in amplification factor on the audio amplifier. A simple solution is to place a 6.8Kohm resistor in parallel over R238. This is for increasing the amplification factor for the audio signal that comes via the LPC4357 DAC output. For audio signals coming from the audio codec, placing a 6.8Kohm resistor in parallel over R236 will correct that signal, if needed.

The picture below locates R238 and R236 on the *OEM Base Board*.

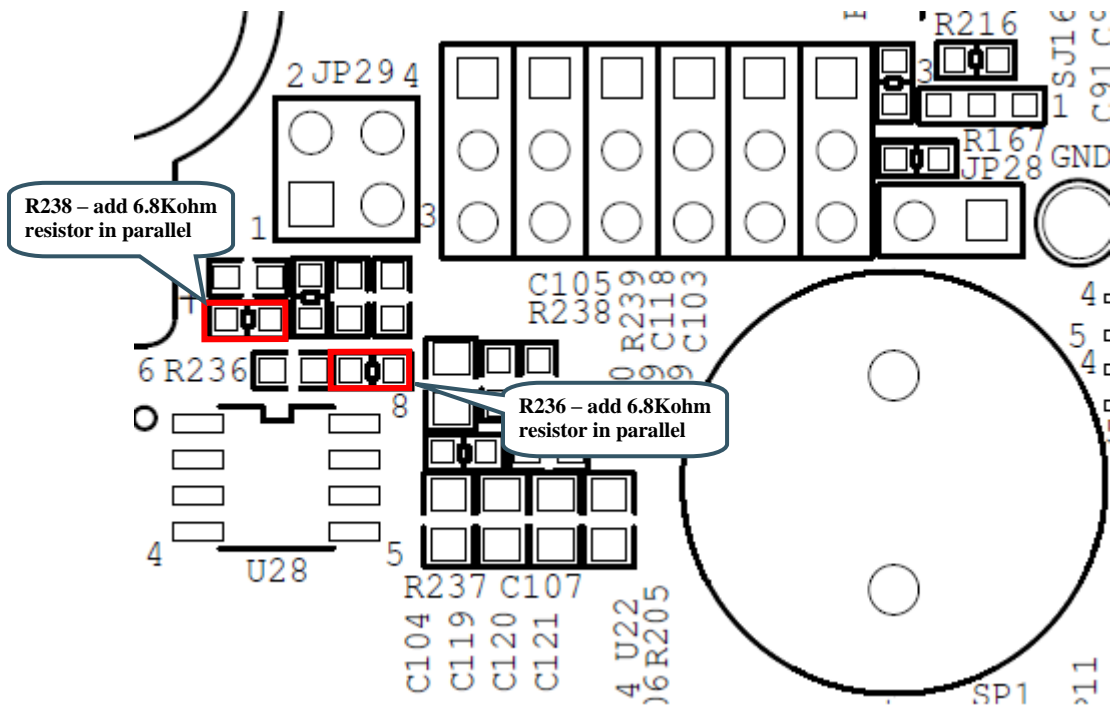

Figure 34 – R236/R238 Location on OEM Base Board, rev C

### 5.6.2 Humming in Speaker

In some situations there can be a humming sound from the on-board speaker. This is because of high-frequency noise on signal GPIO40\_AOUT. The layout in the base board has not been design for lowest possible noise. If the sound is disturbing, just remove both jumpers in JP29 (see section 4.25 for locating the jumpers). Alternatively, add a 100nF ceramic capacitor in parallel to R239. See Figure 35 below where to locate R239. The capacitor will create a low-pass filter removing the noise in the audible region.

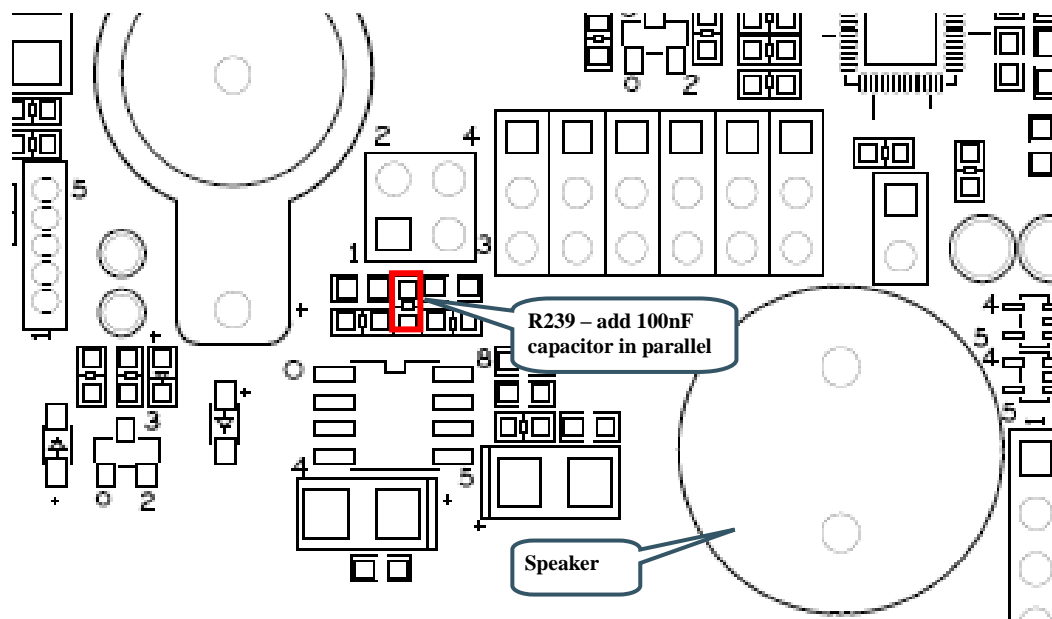

Figure 35 – Speaker Amplifier, U28

### 5.6.3 Current Consumption and Limits of USB Ports

The current consumption of *LPC4357 OEM Board*, *OEM Base Board*, and the *4.3 inch LCD Board* is in the region of 450-525mA. This is very close to what a normal USB-A port can supply. If the boards are powered from a USB-A port (for example a PC or laptop) and there are problems, like spontaneous resets or other strange things, it is likely that an external power supply is needed.

**When using the 7 inch LCD Board an external power supply is always needed.**

### 5.6.4 LCD flickering

When using the LCD expansion interface, R163 must be removed on the *OEM Base Board*. If not, the LCD can start flickering and the blue component of the pixel color can disappear for short time periods (= the flickering). If the picture is mainly blue it will look like a black row on the display. If other colors are dominating on the picture shown, it can also look like yellow lines (white minus block color component result in a yellow color).

The reason for this problem is that the I2C interface of the MIC2555 USB OTG transceiver is connected to the two MSB signals of the blue color component. Even though the pixel data is very much out of spec for the I2C interface, the MIC2555 reacts on some sequences and start driving the MSB signal low, which is the flickering that is seen. The solution is to remove resistor R163.

The LCD interface and the USB OTG transceiver cannot be used at the same time on the *OEM Base Board*.

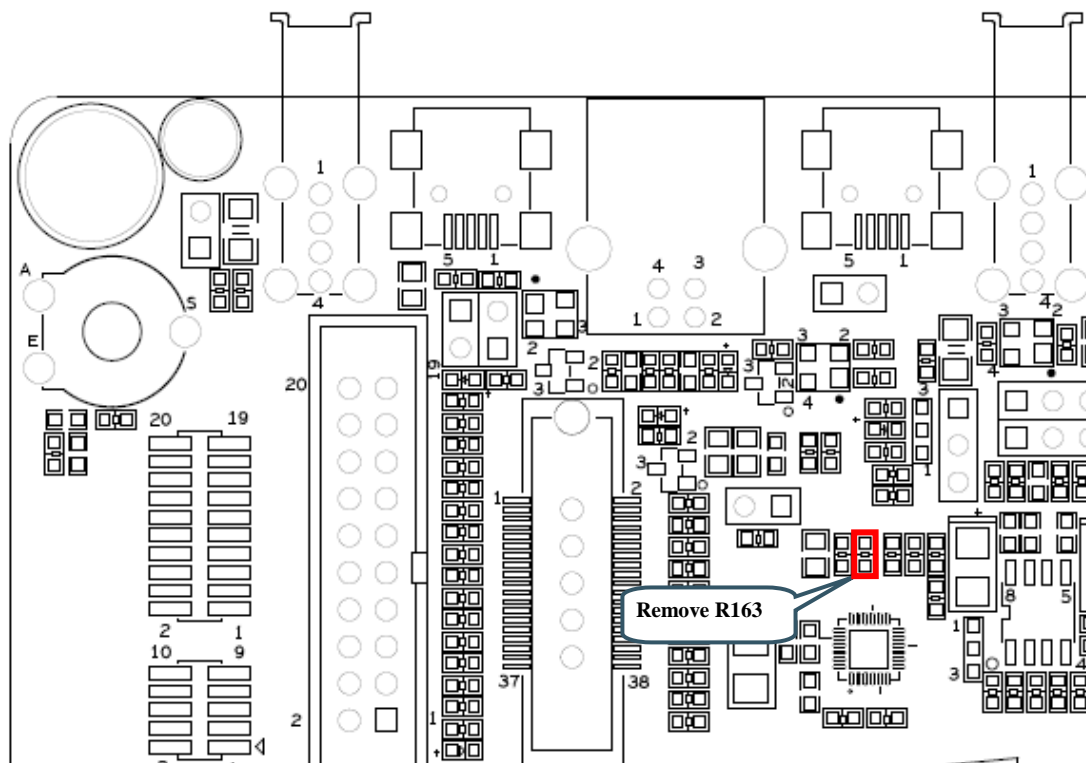

Figure 36 – Identifying R163

**Note that R163 has been removed on all boards shipped out from Embedded Artists after May 15, 2012.** Since there is a transition period, and stock at distributors, there is no guarantee that the resistor has been removed on boards delivered after this date. Please always check if the board has R163 removed. If not, remove R163.

### 5.6.5 Initialization of External Memory Bus

The databus buffers (U12, U14 on LPC4357 OEM board) to the external memory bus are controlled by the OE and BLSx signals. Even though the external memory bus is not used, OE and BLSx are reserved and cannot be used for other purposes. This is also true if only the SDRAM is used but not the static memory areas. The BLS0, BLS1, BLS2 and BLS3 must be set as outputs and set high in order not to enable the databus buffers.

It is recommended to initialize the EMC peripheral and associated pins fully (for both SDRAM and static memory regions).

### 5.6.6 USB OTG Transceiver

The USB OTG transceiver (U31, MIC2555) exists in two versions, -0YML and -1YML. Either one can be mounted on the *OEM Base Board*. The difference is the I2C address that the chip answers to. Any software using the MIC2555 must check which I2C address the chip responds to.

### 5.6.7 External SDRAM Clock Frequency and CLK2\_OUT

This note applies for LPC4357 OEM board, revision A1. See also separate note on product page for the board.

Signal CLK2\_OUT (pin CLK2 on the LPC4357) is available at SODIMM pad/pin 115 on the LPC4357 OEM board. When the external SDRAM is used, signal CLK2\_OUT cannot be used for anything. It is an SDRAM clock signal and any distortion on the signal will affect SDRAM operation.

Signal CLK2\_OUT can only be used as a general clock signal if the external SDRAM is not used/activated. If external SDRAM is not used on the LPC4357 OEM board then there are no limitations on the core clock frequency of the LPC4357. It can run at up to 204 MHz.

On the OEM base board (on which the LPC4358 OEM board is mounted) SODIMM pad/pin 115 is connected to signal GPIO68\_I2S-MCLK, which is routed a long distance over the base board. This will distort the CLK2\_OUT signal seen by the LPC4357 and, as a result, limit the core clock operating frequency when the external SDRAM is used. The problem limits the frequencies to 96/96MHz (core/emc frequency) and 144/72MHz.

By following the solutions outlined in the separate note document, full operating speed can be achieved, which means 102/102MHz and 204/102MHz operation.

### 5.6.8 JTAG/SWD Connection Problems

**Note that JP4 shall be shorted in order to enable the JTAG/SWD interface on the LPC4357.** JP4 might not be inserted by default on the OEM Base Board.

### 5.6.9 I2C-address of E2PROM with EUI-48™ Number

Note that the E2PROM, 24AA02E4 containing the unique 48-bit number (EUI-48™), answers on all I2C addresses in the range 0xA0-0xAF (and not only to address 0xA0/0xA1). No other I2C devices that answers to addresses in this range can be connected to the same I2C channel.



## 6 LCD Expansion Connector

Embedded Artists supplies many different display options as add-on boards. These display boards are great to use for getting started quickly and test a specific display resolution in an application. All LCD boards supplied from Embedded Artists use the LCD Expansion Connector. There is also an option to connect custom displays via the LCD Expansion Connector, J26.

The *OEM Base Board* contains a buffered LCD expansion interface via a 50 pos IDC connector, J26. The expansion interface also includes UART (see UART multiplexing), I2C and SPI interfaces. These additional interfaces are for identifying external displays (via configuration I2C-E2PROM) as well as touch screen controllers. An external LCD pixel clock can also be supplied via the expansion connector.

The LCD expansion connector carries 18 data bits per pixel by default (6 per RGB color). The LPC4357 LCD controller can produce 24 data bits per pixel and it is possible to output all these signals on the LCD expansion connector. The trade-off is that the UART and I2C serial interfaces have to be removed. Via SJ6-SJ11 it is possible to select what signals to make available on the LCD expansion connector. By default pad 1-2 are connected on SJ6-SJ11.

For performance reasons (on the LPC4357), a system with 16-bit color information per pixel is typically what is implemented. A 565-system is most commonly used. This means 5 bits for red, 6 for green and 5 for blue - 16 bits in total. 24-bit systems will double to load on the external memory bus since each pixel is stored as 32-bits (instead of 16-bits, or fewer).

Note that the LCD Expansion Connector only supports connecting to a display via the RGB interface. Some lower resolution displays have the option to connect via a memory bus-like interface, typically 8 or 16-bit. If a memory bus-like interface shall be used, use the external memory bus available via expansion connector J4 instead.

There are many steps to consider when connecting a custom LCD to the LCD Expansion Connector.

- As a first step, the pixel color signals must be matched between the LPC4357 and display. The LPC4357 has many options for routing the pixel data to different pins and there are differences depending on the display mode selected. The *OEM Base Board* supports the default settings when using TFT 4:4:4 or TFT 5:6:5-mode. For 24-bit systems, the extra serial interfaces on the LCD Expansion Connector must be traded-off.
  - Many displays have 24 or 18 bit color interfaces, i.e., 8 or 6 bits per color. This means that some color information is missing when using TFT 4:4:4 or TT5:6:5-mode. Always connect the available color bits from the LPC4357 to the MSB bits. A common solution is to connect the most significant color bit to the missing (LSB) bits. Alternatively, just ground the LSB bits.
  - The table below lists where the pixel color information can be found when working in TFT 4:4:4 or TFT 5:6:6 mode.

<b>LCD-VD bit in LCD Expansion Connector, J26</b>	<b>J26 pin</b>	<b>TFT 4:4:4 mode</b>	<b>TFT 5:6:5 mode</b>
LCD_VD3	25 Note JP34 in position 2-3		RED0 (LSB)
LCD_VD4	7	RED0 (LSB)	RED1
LCD_VD5	8	RED1	RED2

LCD_VD6	9	RED2	RED3
LCD_VD7	10	RED3 (MSB)	RED4 (MSB)
LCD_VD10	15		GREEN0 (LSB)
LCD_VD11	16		GREEN1
LCD_VD12	17	GREEN0 (LSB)	GREEN2
LCD_VD13	18	GREEN1	GREEN3
LCD_VD14	19	GREEN2	GREEN4
LCD_VD15	20	GREEN3 (MSB)	GREEN5 (MSB)
LCD_VD19	26		BLUE0 (LSB)
LCD_VD20	27	BLUE0 (LSB)	BLUE1
LCD_VD21	28	BLUE1	BLUE2
LCD_VD22	29	BLUE2	BLUE3
LCD_VD23	30	BLUE3 (MSB)	BLUE4 (MSB)

- The HSYNC, VSYNC, DEN control signals and the DOTCLK pixel clock signals must be connected to the display. All displays typically require the DOTCLK signal but there are variations on the control signals.
  - Some displays require all three control signals (HSYNC, VSYNC, DEN).
  - Some displays require only HSYNC and VSYNC.
  - Some displays require only DEN control signals.
  - Some displays require that HSYNC is delayed compared to VSYNC, i.e., VSYNC must have a falling edge before HSYNC (assuming that HSYNC/VSYNC are active negative). If this is needed, HSYNC can be delayed one DOTCLK cycle with two D-type flip-flops.
- In most cases the LPC4357 can generate the appropriate DOTCLK frequency. The higher the frequency needed, the fewer available frequencies can be selected when dividing the core clock. If a specific frequency is needed, the GP\_CLKIN (pin PF\_4) signal can be used. It is an input to the LPC4357. If not used, just leave PF\_4 unconnected.
  - Most displays can accept a quite wide range of frequencies on the DOTCLK signal.
- Some displays has a serial interface (typically SPI-like) for initialization of the controller chip inside the display. This is relatively common for smaller QVGA-sized displays but larger (resolution above QVGA – 320x240) displays typically do not require this initialization.
  - The LCD Expansion connector has an SPI interface that supports both 3-wire transfer and 4-wire transfers. A 3-wire SPI interface typically means that 9 data bits are transferred in every time, 8 data bits and one bit indicating if it is a command or data byte. SPI-CLK, SPI-MOSI and SPI-SSEL are needed, i.e., 3 signals. For a 4-wire interface the transfers are 8 bits and a separate signal (the fourth wire) is used to signal if it is a command or data transfer. Signal SPI\_LCD\_DC is typically used for this. Few displays allow for read back of internal control registers via SPI. Only write transfers are typically supported.

- Many displays have strict requirements of power sequencing during power up and down. Embedded Artists display boards has an I2C-GPIO expansion chip (PCA9532) and voltage control of +3.3V and +5V to allow power sequencing.
  - Embedded Artists recommend that the power sequences outlined in the display datasheets are followed for best long term performance of the display.
- For simplicity, Embedded Artists has added a configuration i2c-e2prom in the display add-on boards that contains information about the connected display. This simplified development of portable software.
  - A standard 24LC64 chip is used with i2c-address 0xAC/AD (1.0.1.0.1.1.0.rw). A0 on the chip is connected to GND and A1/A2 to VCC to get address 0xAC/AD.
- Some displays also require a reset signal after VCC/VDD has stabilized. In that case the I2C-GPIO expansion chip can be used to create this signal. Alternatively a free GPIO signal in the LCD Expansion Connector can be used.
- All TFT LCDs must have a control for backlight. A constant current source is needed. Some displays have one LED string while others have 2-4 strings making control slightly more complicated.
  - OLEDs do not require separate backlight since the pixels transmit light themselves.
- As a final step a touch screen interface is typically needed.
  - Embedded Artists display boards often use the TSC2046 from TI. It has a simple SPI interface.
  - Capacitive touch screen controllers typically have I2C or SPI interfaces.
- Do not forget that some displays have configurations pins for selecting interface type functionality.

## 7 Troubleshooting

This chapter contains information about how to troubleshoot boards that does not seem to operate properly. It is strongly advised to read through the list of tests and actions that can be done before contacting Embedded Artists. The different tests can help determine if there is a problem with the board, or not. For return policy, please read Embedded Artists' General Terms and Conditions document (can be found at <http://www.embeddedartists.com/shop/>).

### 7.1 No SWD/JTAG Connection

**Note that JP4 must be shorted (jumper installed) in order to enable the JTAG/SWD interface on the LPC4357.** JP4 might not be inserted by default on the OEM Base Board.

### 7.2 Powering

The first step is to make sure that powering works properly. The input power interface is described in section 4.23 .

1. Disconnect the powering and removed the *OEM Board*, i.e., remove it from the socket (J1). All other connections to the *OEM Base Board* shall also be removed.
2. Connect a stable DC supply (+5V, positive center) to J24. Minimum current capability shall be 1A for this test. The noise level should be minimal, less than 50mV.
3. Measure the +5V and +3.3V voltages with the help of the voltage measuring pads on the *OEM Base Board*.  
Acceptable range for the +5V voltage is 4.5V to 5.5V.  
Acceptable range for the +3.3V voltage is +3.2V to +3.4V.  
If the reset-LED is dimming instead of being clearly on or off, it is also a sign that the supply voltages are not stable and outside of valid ranges.  
If problem; since the *OEM board* is disconnected and there is normally no big current consumption on passive *OEM Base Board*, it is likely that some part of the *OEM Base Board* consumes a lot of current. It might be possible to locate the faulty section/component by checking component temperatures with the finger tip. Be careful because faulty components can get very hot.
4. Verify that there are no voltage dips on the supply. A typical indication of this is that the reset-LED flash from time to time. An oscilloscope can detect voltage dips; measure the supply voltage in AC mode. Set horizontal resolution to 50mV per square. Set the trigger to normal mode and adjust the trigger to 50mV below the normal level. That way, the oscilloscope will trigger every time a voltage dips occurs. By watching the dips it is possible to judge if there is a problem, or not.
5. Verify that the reset-LED flash when pressing the reset push-button. The LED should also light shortly after releasing the push button. The extra "LED on time" is very short but still noticeable (typically a 1/5 of a second, i.e., 200mS).
6. Disconnect the powering and mount the *OEM Board* again (in J1).  
Now, measure the +5V and +3.3V voltages again (see step 2 above). If the +5V voltage is below acceptable range it is a sign of too weak power supply to the board. If the reset-LED starts dimming instead of being clearly on or off, it is also a sign of too weak power supply to the board.  
If the reset-LED always light now when the *OEM Board* is mounted it is a sign of too weak power supply or a serious error on the *OEM Board*. When doing this test, be sure to not have any SWD/JTAG interface connected or any external source driving the reset signal.  
Verify that the reset-LED flash when pressing the reset push-button.
7. In section 4.3 it is described how to measure the current consumption of the *OEM Board*. Measure the voltage over J2 while pressing the reset push-button constantly. This will give

the passive current consumption of the *OEM Board*, i.e., when the board is in reset. Valid range is 100-350mV (which corresponds to 20-70 mA). If current consumption is outside of this range, it is an indication that something can be wrong with the *OEM board*. Note that the valid range is quite wide. Being outside this does not necessarily mean that something is wrong. More symptoms than this is needed to judge if a board is wrong, or not. Do not forget to press the reset push-button all the time during this measurement. Redo the test in case of uncertainty.

8. Now, measure the current consumption of the *OEM Board* when it is running an application. It is a problem to not have a specified application running because the current consumption can vary widely between different applications. The current consumption shall increase compared to the previous test (in case an application is running). It is recommended to download one of the precompiled sample applications from the LPC4357 Developer's Kit support page on the Embedded Artists web site. How to download is explained in next section. The sample application `s_sdram.hex` has for example a known current consumption range. The valid range is 650-900mV (which corresponds to 130-180mA). The current consumption varies between different sample applications depending on which peripherals that are active. A running application will in general give a range of 400-700mV (which corresponds to 80-140mA)
9. In most cases it is possible to power the board via the USB interface, J25 (the UART-to-USB bridge mini-B USB connector). Redo tests 3) to 8) above again with USB powering. Connect J25 directly to a PC with the USB cable included in the Developer's Kit.  
Note that not all PC:s and/or laptops can power the board. In such cases, a USB hub with independent powering can work. In this case, connect J25 to a USB Hub, which in turn is connected to a PC.

### 7.3 Contact with OEM Board MCU

The second step is to make sure that the LPC4357 MCU on the *OEM Board* is working.

Test that it is possible to download one of the precompiled test programs that exist on Embedded Artists support site. Use the DFUsec application to download code over USB. See section 5.4.1 for details how to download.

Optionally test that it is possible to download via the JTAG/SWD interface. A JTAG/SWD debug interface is then needed. The low-cost LPCXpresso target board series from NXP contains a JTAG/SWD debug interface called LPC-Link™ that can be used for this. Other brands will also work.

### 7.4 Using Test Program to Verify Correct Operation

The third step is to utilize the just downloaded precompiled sample applications, one after one, to verify correct operation of individual parts of the *OEM Board* as well as the *OEM Base Board*. While doing these tests, be sure to not have anything connected to the system.

## 8 Further Information

The LPC4357 microcontroller is a complex circuit and there exist a number of other documents with a lot more information. The following documents are recommended as a complement to this document.

- [1] NXP LPC4357 Datasheet  
[https://www.nxp.com/docs/en/data-sheet/LPC435X\\_3X\\_2X\\_1X.pdf](https://www.nxp.com/docs/en/data-sheet/LPC435X_3X_2X_1X.pdf)
- [2] NXP LPC4357 User's Manual  
<https://www.nxp.com/docs/en/user-guide/UM10503.pdf>
- [3] NXP LPC4357 Errata  
[https://www.nxp.com/docs/en/errata/ES\\_LPC435X\\_3X\\_2X\\_1X\\_FLASH.pdf](https://www.nxp.com/docs/en/errata/ES_LPC435X_3X_2X_1X_FLASH.pdf)
- [4] ARM Processor Documentation  
Documentation from ARM can be found at: <http://infocenter.arm.com/>.
- [5] Information on different ARM Architectures  
<https://developer.arm.com/products/architecture>
- [6] ARMv7-M Architecture Reference Manual. Document identity: DDI 0403D  
<http://infocenter.arm.com/help/index.jsp?topic=/com.arm.doc.ddi0403c/index.html>
- [7] Cortex-M4 Technical Reference Manual. Revision: r0p1  
<http://infocenter.arm.com/help/index.jsp?topic=/com.arm.doc.ddi0439c/index.html>
- [8] LPCXpresso IDE / MCUXpresso: NXP's low-cost development platform for LPC families, which is an Eclipse-based IDE.  
<http://nxp.com/lpcxpresso>  
<http://nxp.com/mcuxpresso>

Note that there can be newer versions of the documents than the ones linked to here. Always check for the latest information/version.