



## Embedded Artists AB

Davidshallsgatan 16  
SE-211 45 Malmö  
Sweden

[info@EmbeddedArtists.com](mailto:info@EmbeddedArtists.com)  
<http://www.EmbeddedArtists.com>

### **Copyright 2005-2012 © Embedded Artists AB. All rights reserved.**

No part of this publication may be reproduced, transmitted, transcribed, stored in a retrieval system, or translated into any language or computer language, in any form or by any means, electronic, mechanical, magnetic, optical, chemical, manual or otherwise, without the prior written permission of Embedded Artists AB.

### **Disclaimer**

Embedded Artists AB makes no representation or warranties with respect to the contents hereof and specifically disclaim any implied warranties or merchantability or fitness for any particular purpose. Information in this publication is subject to change without notice and does not represent a commitment on the part of Embedded Artists AB.

### **Feedback**

We appreciate any feedback you may have for improvements on this document. Please send your comments to [support@EmbeddedArtists.com](mailto:support@EmbeddedArtists.com).

### **Trademarks**

All brand and product names mentioned herein are trademarks, services marks, registered trademarks, or registered service marks of their respective owners and should be treated as such.

# Table of Contents

<b>1</b>	<b>Document Revision History</b>	<b>4</b>
<b>2</b>	<b>Introduction</b>	<b>5</b>
2.1	Features	5
2.2	ESD and Handling Precaution	5
2.3	Other Products from Embedded Artists	5
2.3.1	Design and Production Services	5
2.3.2	OEM / Education / QuickStart Boards and Kits	6
<b>3</b>	<b>Getting Started</b>	<b>7</b>
3.1	LPCXpresso	7
3.2	Initial Preparation – Soldering of Connectors	7
3.3	Board Powering	10
3.4	Main Components	11
3.4.1	LPCXpresso / mbed Signals	11
3.4.2	100 mil Pitch Holes	13
3.4.3	50 mil Pitch Holes	14
3.4.4	50 mil Pitch SOIC Components	15
3.4.5	0.65 mm Pitch SSOP Components	16
<b>4</b>	<b>Mechanical Dimensions</b>	<b>17</b>

# 1 Document Revision History

<i>Revision</i>	<i>Date</i>	<i>Description</i>
PA1	2010-02-02	First complete version.
PA2	2011-05-20	Added errata information (silk screen print) in section 3.4.1.
A	2012-01-18	Added clarification that pin names refer to LPC1114 and LPC1343 (and not to for example LPC1769 and LPC1227).

## 2 Introduction

Thank you for buying Embedded Artists' *LPCXpresso Prototype Board*, designed for the *LPCXpresso Board* (for many different target boards in the LPC1xxx family) and the *mbed* module from NXP's.

This document is a User's Guide that describes the *LPCXpresso Prototype Board* hardware design. The general focus will be for the *LPCXpresso* boards but differences for the *mbed* module will be noted.

### 2.1 Features

The *LPCXpresso Prototype Board* makes it possible for you to get started with experiments and prototyping immediately with the *LPCXpresso Board*. The *LPCXpresso Prototype Board* can also be used together with the *mbed* module. The features of the *LPCXpresso Prototype Board* are:

- All signals on expansion connector can be accessed easily
- Includes two 1x27 pin lists and two 1x27 headers  
*Note that these must be manually soldered to the LPCXpresso (LPC1xxx) board and the LPCXpresso Prototype board, respectively.*
- Large prototype area with 100mil pitch holes
- Prototype area with 50mil pitch holes
- Prototype area for 50 mil pitch SOIC components
- Prototype area for 0.65 mm pitch SSOP components
- Dimensions: 148 x 120 mm

### 2.2 ESD and Handling Precaution

Please note that the *LPCXpresso Prototype Board* itself is not sensitive to ESD (Electro-Static Discharge) simply because there are no components mounted on the board. However, as soon as the board contains prototype electronics and/or have the *LPCXpresso Board* mounted, pay attention to ESD precaution.

***Make it a habit to always first touch a ground point (for example the metal surface of the USB connector on the LPCXpresso Board) for a few seconds with both hands before touching any other parts of the boards.*** That way, you will have the same electrical potential as the board and therefore minimize the risk for ESD.

***Note that Embedded Artists does not replace boards that have been damaged by ESD.***

### 2.3 Other Products from Embedded Artists

Embedded Artists have a broad range of low cost LPC1xxx/LPC2xxx/LPC3xxx/LPC4xxx based boards developed for prototyping / development as well as for OEM applications. Modifications for OEM applications can be done easily, even for modest production volumes. Contact Embedded Artists for further information about design and production services.

#### 2.3.1 Design and Production Services

Embedded Artists provide design services for custom designs, either completely new or modification to existing boards. Specific peripherals and I/O can be added easily to different designs, for example, communication interfaces, specific analog or digital I/O, and power supplies. Embedded Artists has a broad, and long, experience in designing industrial electronics in general and with NXP's LPC1xxx/LPC2xxx/LPC3xxx/LPC4xxx microcontroller families in specific. Our competence also includes wireless and wired communication for embedded systems. For example IEEE802.11b/g (WLAN), Bluetooth™, ZigBee™, ISM RF, Ethernet, CAN, RS485, and Fieldbuses.

### 2.3.2 OEM / Education / QuickStart Boards and Kits

Visit Embedded Artists' home page, [www.EmbeddedArtists.com](http://www.EmbeddedArtists.com), for information about other *OEM / Education / QuickStart* boards / kits or contact your local distributor.

## 3 Getting Started

This chapter contains information about how to get acquainted with the *LPCXpresso Prototype Board*. **Please read this section first before you start using the board - it will be worthwhile!**

### 3.1 LPCXpresso

The main source of information about the LPCXpresso LPC1xxx boards as well as the LPCXpresso Debugger/IDE is <http://www.nxp.com/lpcxpresso>.

This site contains a lot of information, like introduction videos, getting started manual, a forum, link to IDE download and much more information that is related to LPCXpresso.

### 3.2 Initial Preparation – Soldering of Connectors

The *LPCXpresso Prototype Board* is delivered with two pin lists (male) and two headers (female). See Figure 1 to identify the different connectors.

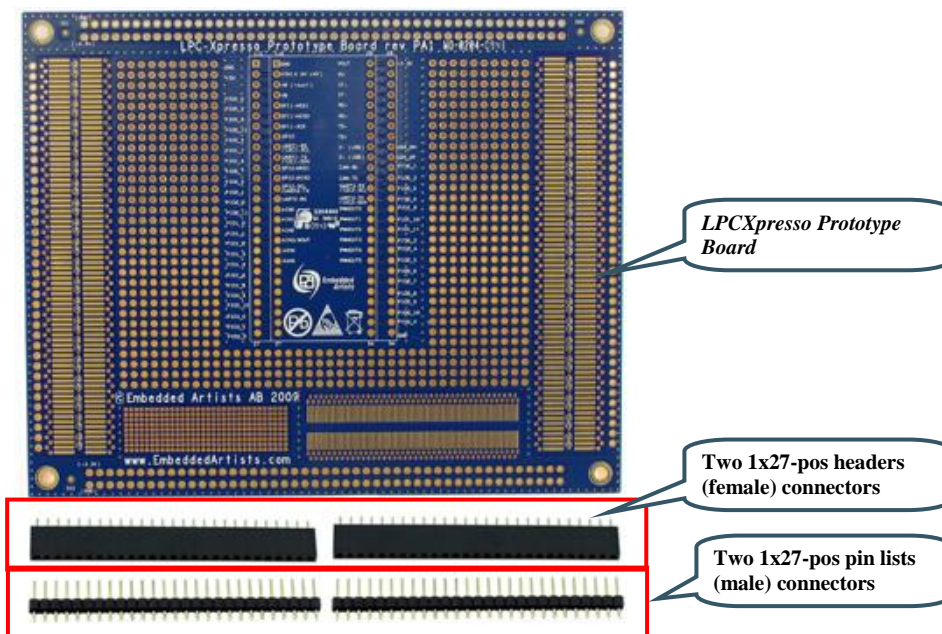

Figure 1 – LPCXpresso Prototype Board Kit Content

The pin lists shall be soldered onto the backside of the *LPCXpresso* LPC1xxx board (as seen in Figure 2 and Figure 3) before it can be used with the *LPCXpresso Prototype Board*. Note that the different target boards look a little bit different but all have the edge connectors like shown in the picture below.

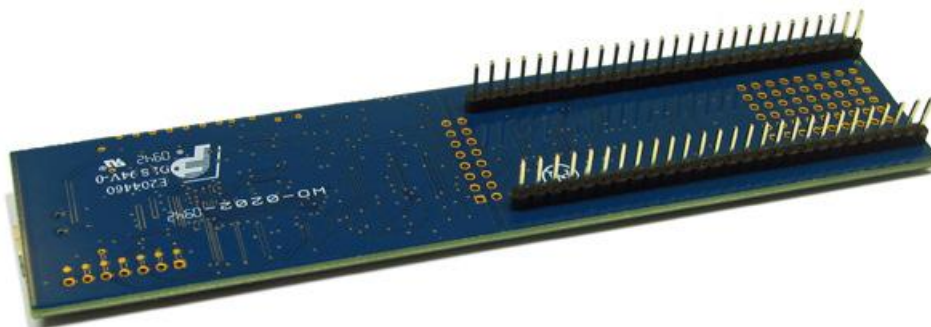

Figure 2 – LPCXpresso Board with Pin Lists Facing Up



Figure 3 – LPCXpresso Board with Pin Lists Facing Down

The headers shall be soldered onto the front side of the *LPCXpresso Prototype Board*, as seen in Figure 4.

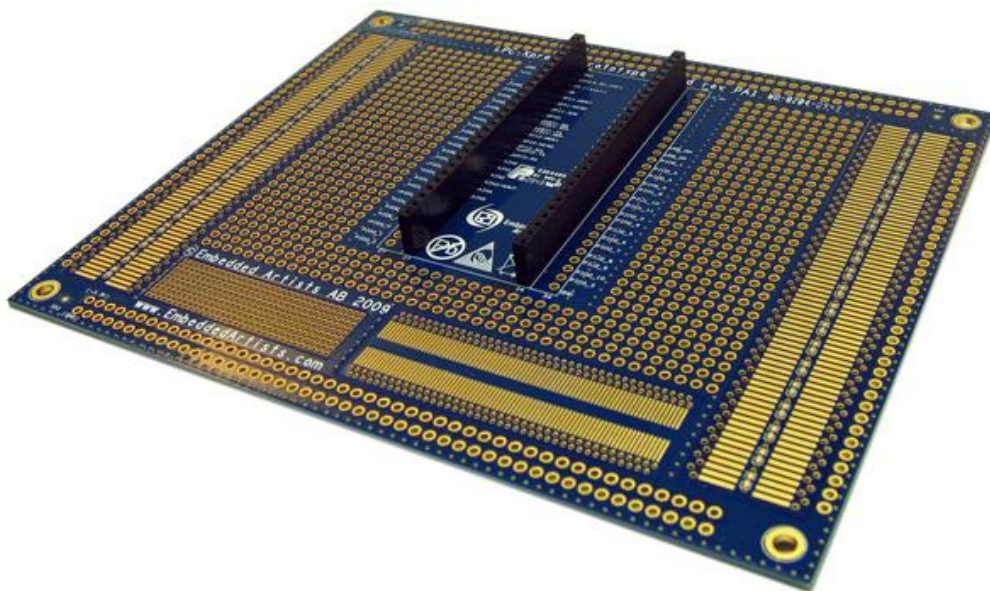

Figure 4 – LPCXpresso Prototype Board with Headers Facing Up

Figure 5 shows the *LPCXpresso Board* mounted in the *LPCXpresso Prototype Board*.

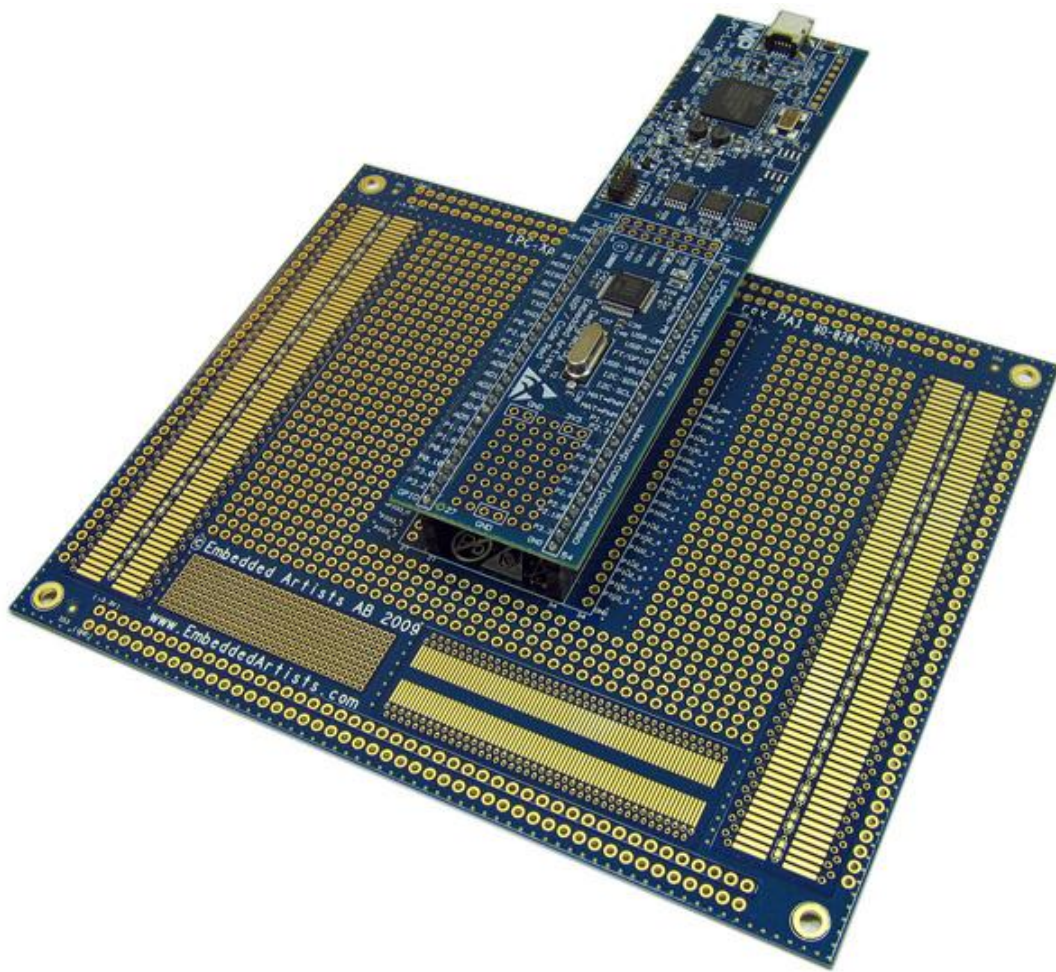

Figure 5 – LPCXpresso Prototype Board with LPCXpresso Board Mounted

### 3.3 Board Powering

The *LPCXpresso Prototype Board* distributes voltages according to Figure 6. The red rectangles illustrate the holes where GND-potential is available. All the areas are connected. The green rectangles illustrate where +3.3V-potential is available. All the areas are connected. The pcb silk screen also indicates where GND and +3.3V is available.

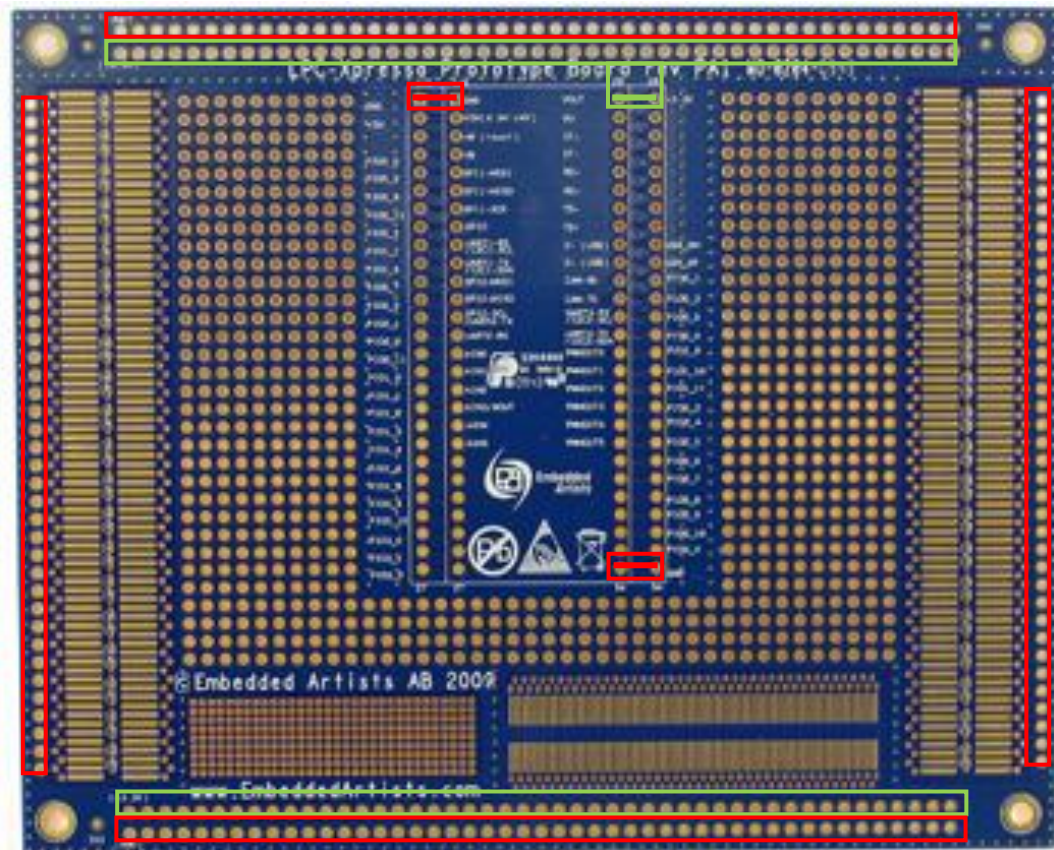

Figure 6 – Board Powering

Note that the “+3.3V” potential is about +3.3V, but slightly lower due to voltage drop from a back-feed protection diode on the *LPCXpresso Board* if the +3.3V is generated on the *LPCXpresso Board*.

These are the powering options for *LPCXpresso*:

- The +3.3V can be generated from the *LPCXpresso Board*.
  - Power can come from a PC via the USB-interface for LPC-LINK.
  - Power can alternatively come from an external +5V source (that connects to VIN on the *LPCXpresso Board*).
- The +3.3V can come from an external source. Note that this power source must be able to handle that the *LPCXpresso Board* also can power the +3.3V.

These are the powering options for *mbed*:

- The +3.3V can be generated from the *mbed* module.
  - Power can come from a PC via the USB-interface on the module.
- Power can alternatively come from an external +5V source (that connects to VIN on the module).

### 3.4 Main Components

This section describes the different areas of the *LPCXpresso Prototype Board*.

#### 3.4.1 LPCXpresso / mbed Signals

All signals on the *LPCXpresso Board* / mbed module are accessed easily just right next to the headers (marked with green rectangles in Figure 7). There is also silk screen text on the pcb listing the signal names. LPCXpresso names are listed outside of the connector area and mbed signal names are listed in-between the headers.

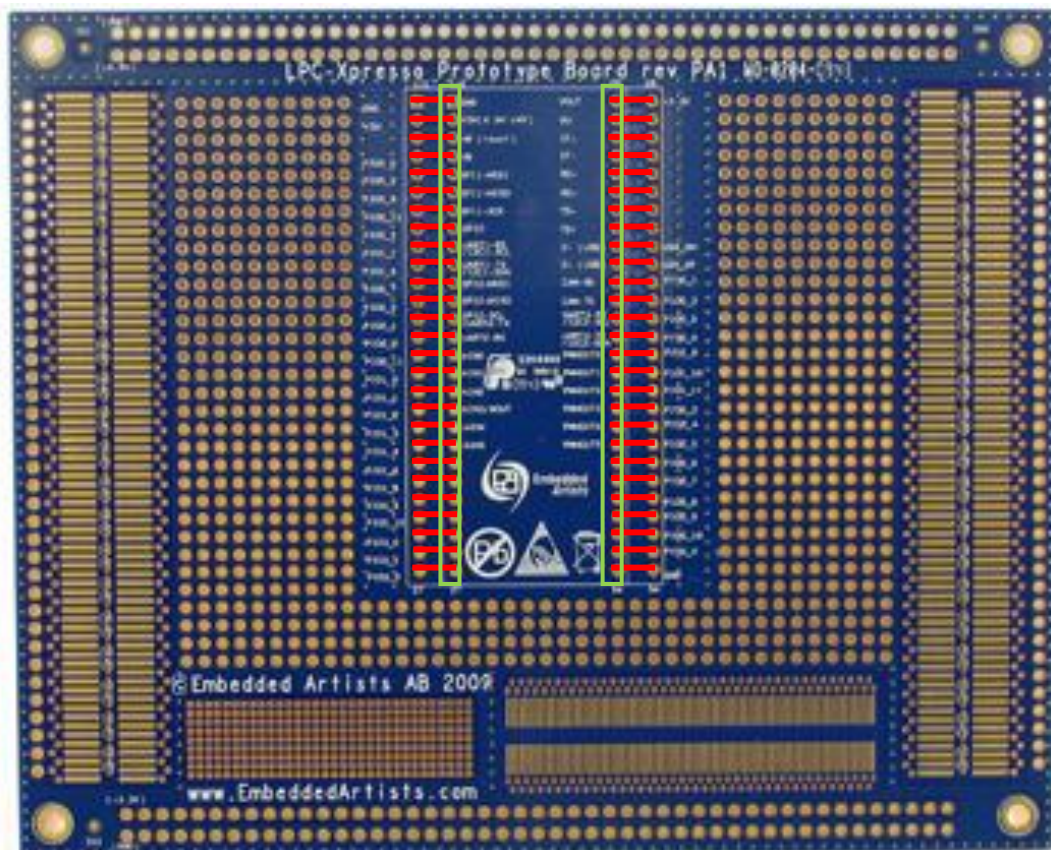

Figure 7 – LPCXpresso / mbed Signals

There are two errors in the silk screen related to the mbed pinning (in-between the headers).

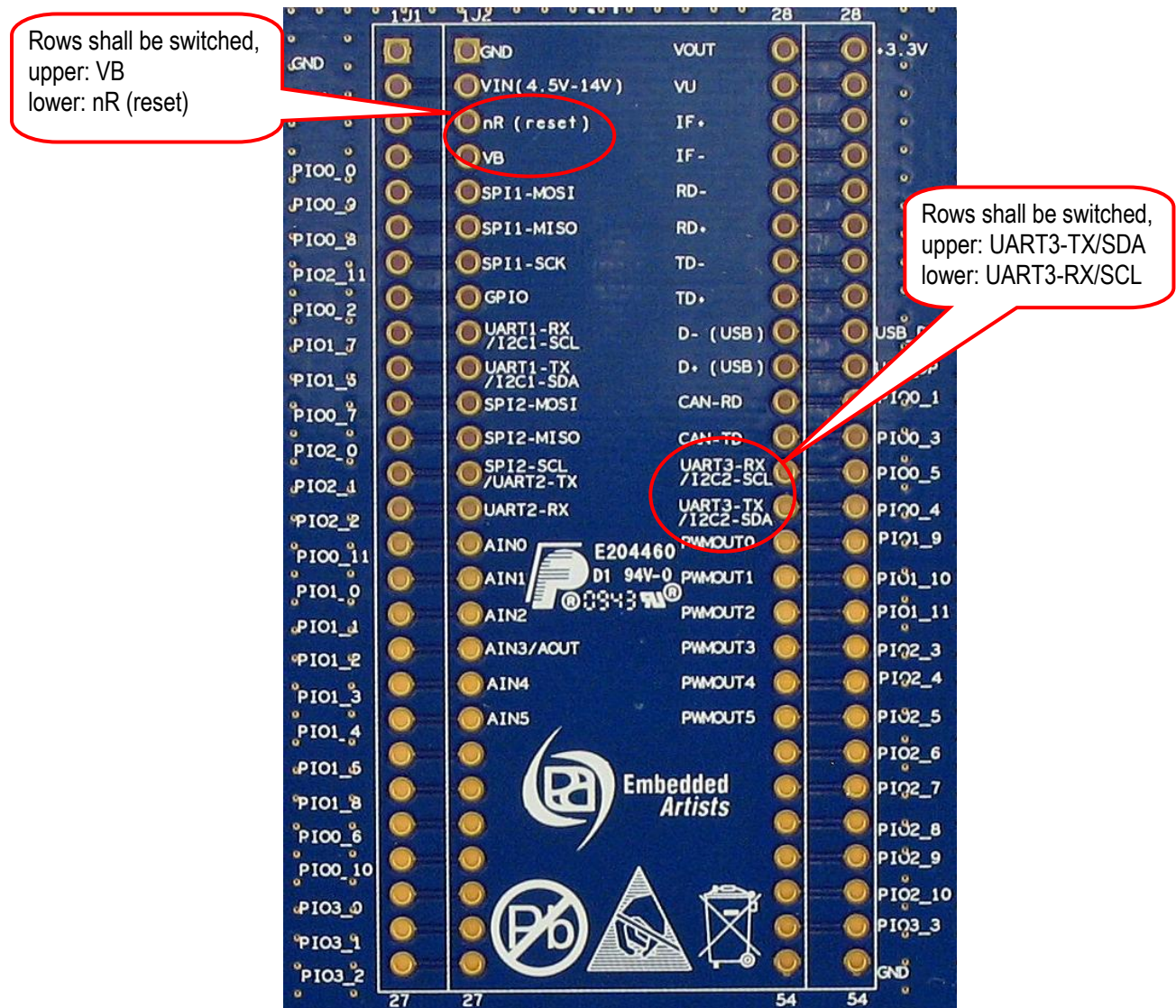

Figure 8 – LPCXpresso / mbed Signal name errata

**Also note that all pin names refer to LPC1114/LPC1343 pin naming. The board was originally designed for these processors. The LPC1769 and LPC1227 pin names are completely different. Check the respective schematic for converting pin names.**

### 3.4.2 100 mil Pitch Holes

A large part of the board is covered with 100mil pitch holes, as indicated in the red area in Figure 9. The holes are 1.09 mm in diameter.

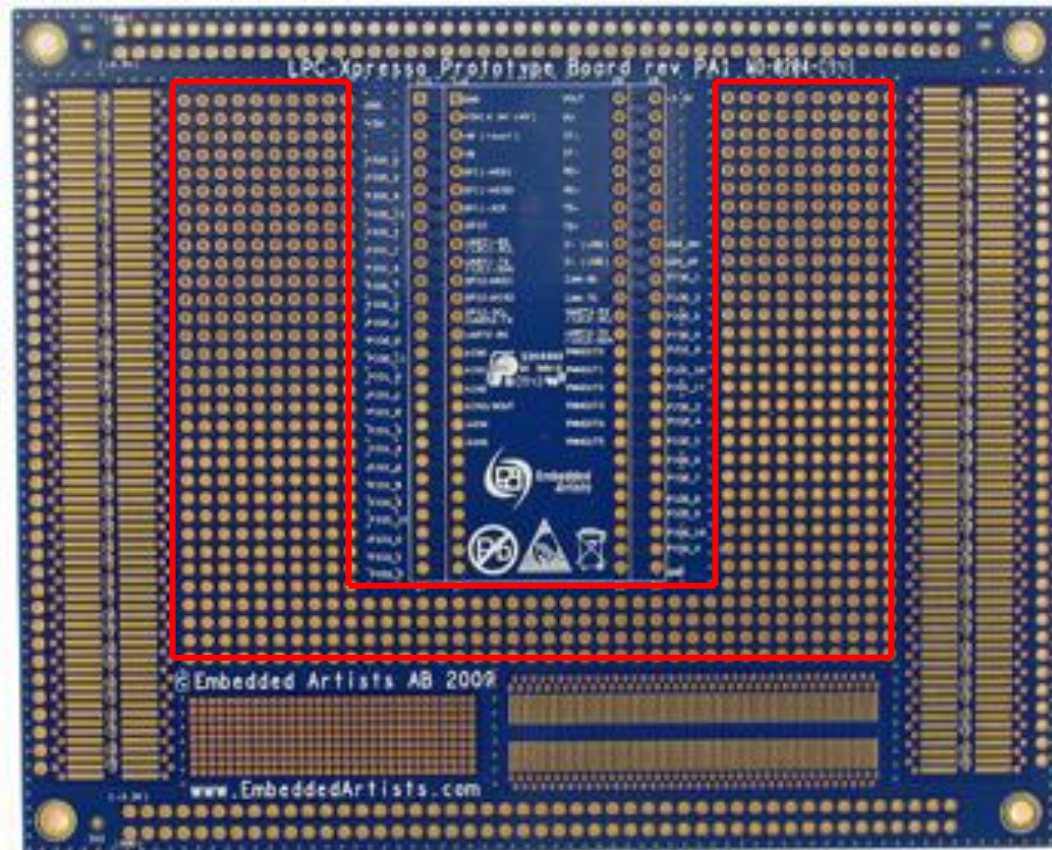

Figure 9 – 100 mil Hole Areas

### 3.4.3 50 mil Pitch Holes

Figure 10 indicates, in the red area, a prototype area with 50 mil pitch holes. The holes are 0.71 mm in diameter.

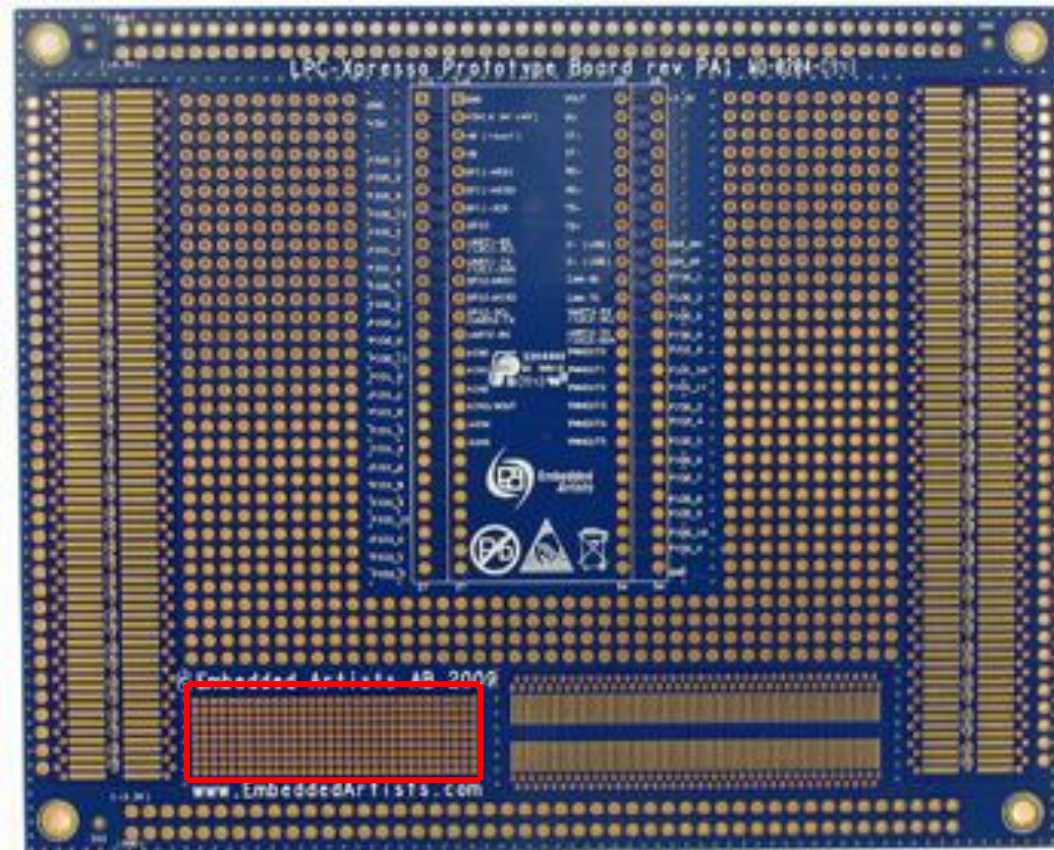

Figure 10 – 50 mil Hole Areas

### 3.4.4 50 mil Pitch SOIC Components

The two red rectangles in Figure 11 indicate prototype areas for 50 mil pitch SOIC components. The SOIC components can have 3.9mm, 5.3mm or 7.5mm (300 mil) wide bodies. Each pad is accessible via a small hole.

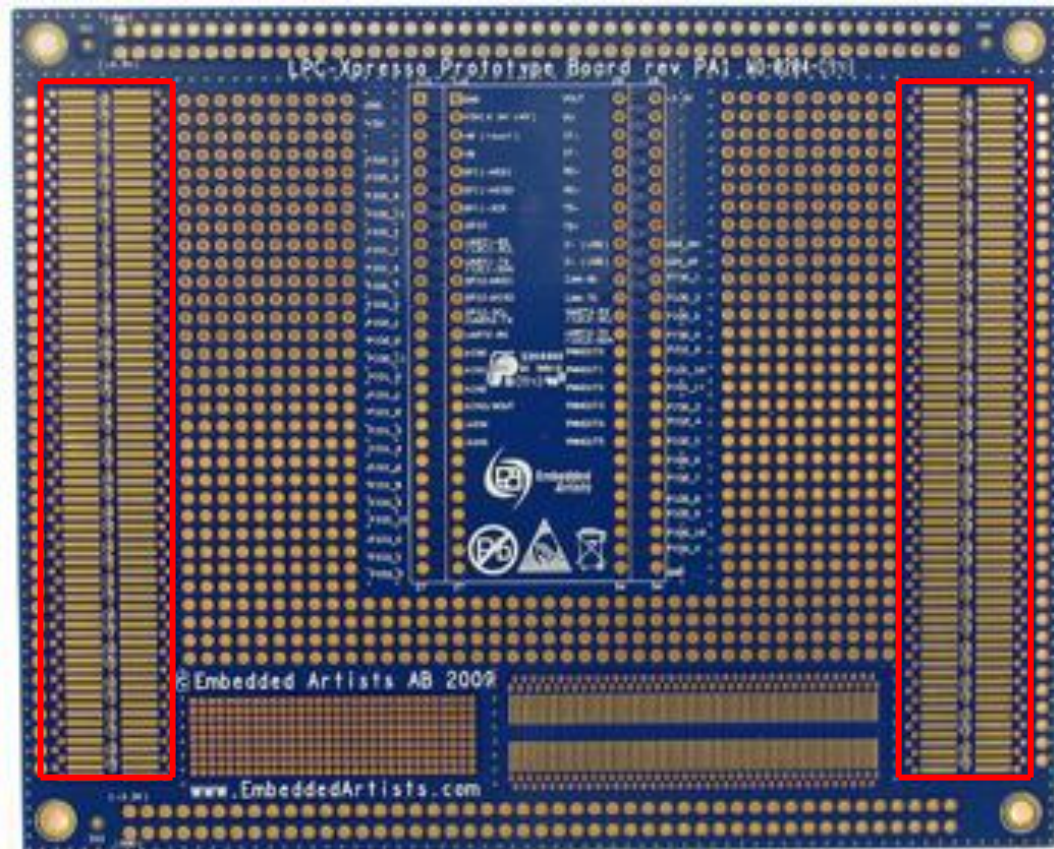

Figure 11 – 50 mil SOIC Areas

In-between the SOIC pads, there are 0603-sized pads for decoupling capacitors. The upper pad on all positions is connected to GND-potential. The lower pad is not connected to anything. It is supposed to connect to any power supply pin on a SOIC package.

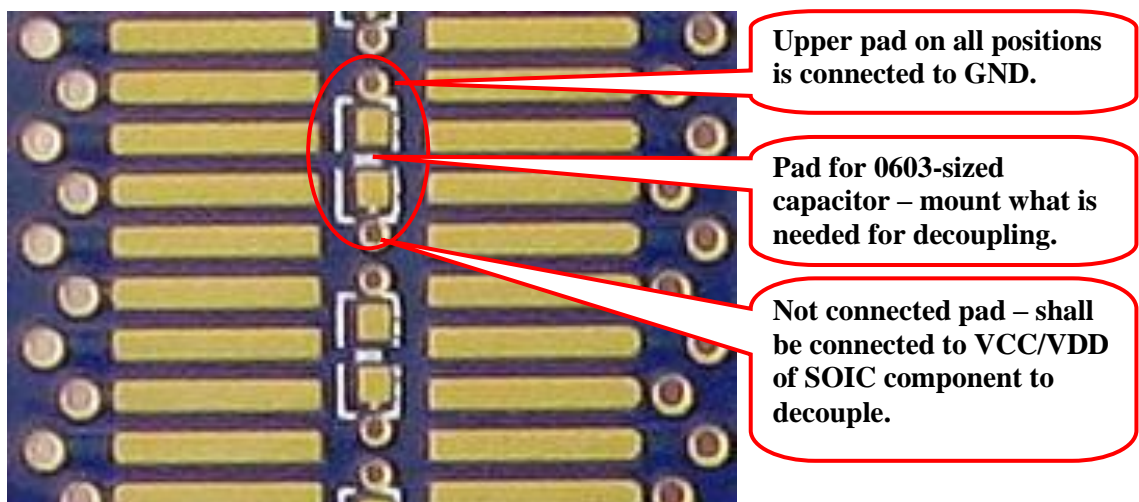

Figure 12 – 0603 pads in SOIC Area

### 3.4.5 0.65 mm Pitch SSOP Components

The red rectangle in Figure 13 indicates a prototype area for 0.65 mm pitch SSOP components. Each pad is accessible via a small hole.

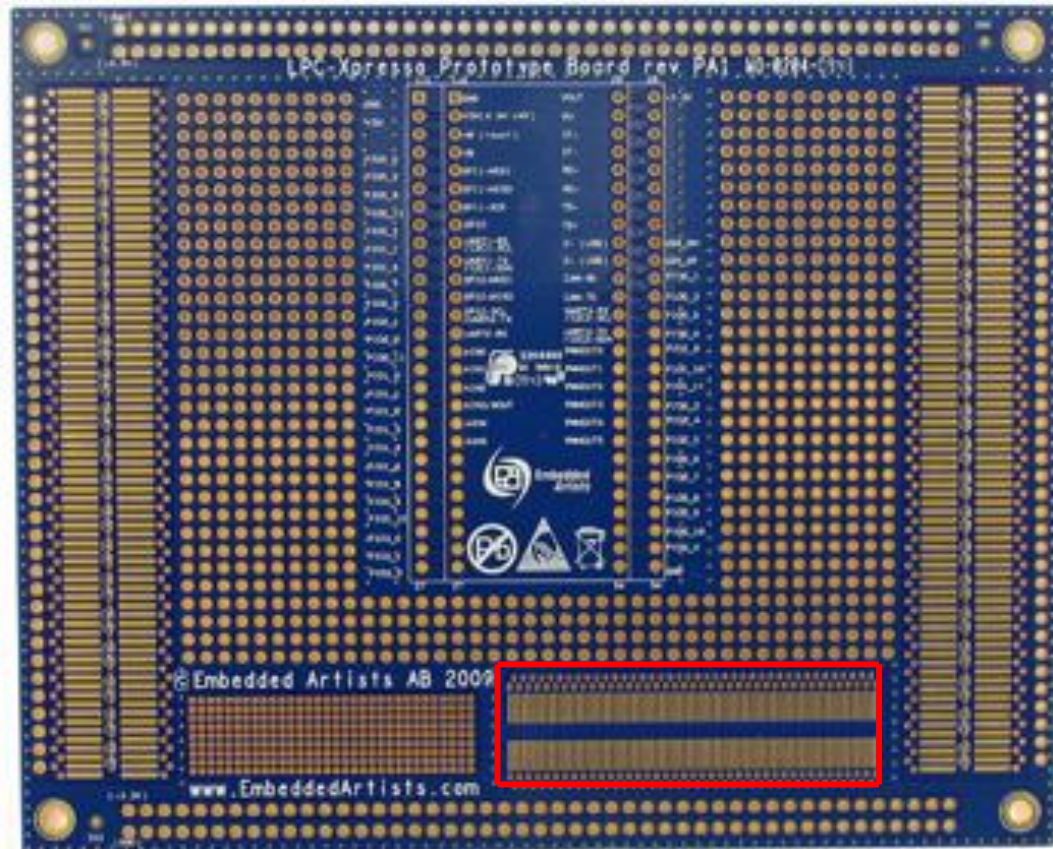

Figure 13 – 0.65 mm SSOP Areas

## 4 Mechanical Dimensions

Figure 14 contains a picture of the board that includes mechanical measures. The connector positions are also marked. The x,y coordinates are given in mil and mm.

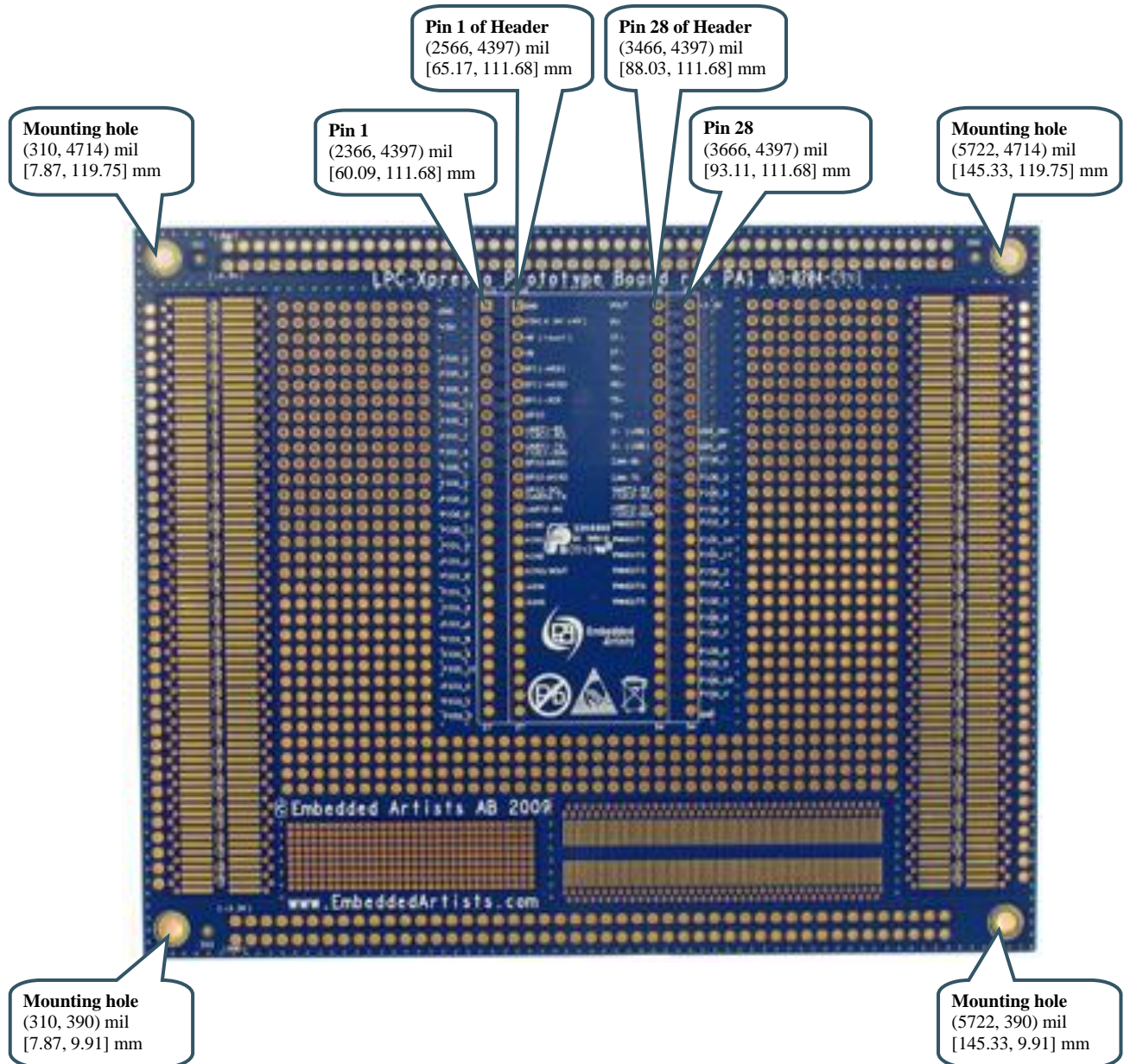

Figure 14 – LPCXpresso Prototype Board Mechanical Dimensions