

## Experiment Expansion Board User's Guide

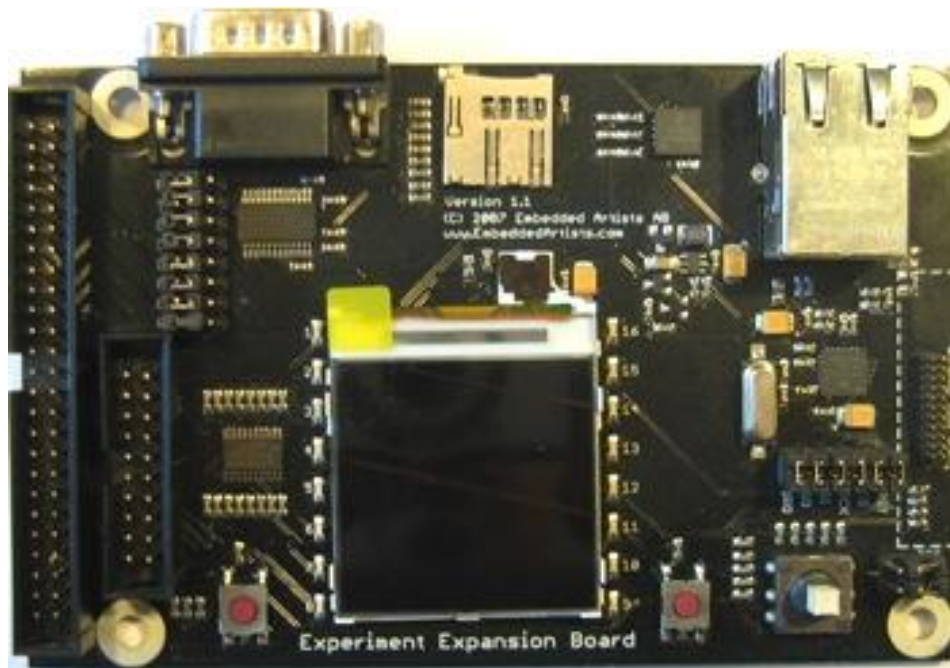

## Embedded Artists AB

Davidshallsgatan 16  
SE-211 45 Malmö  
Sweden

[info@EmbeddedArtists.com](mailto:info@EmbeddedArtists.com)  
<http://www.EmbeddedArtists.com>

### **Copyright 2005-2012 © Embedded Artists AB. All rights reserved.**

No part of this publication may be reproduced, transmitted, transcribed, stored in a retrieval system, or translated into any language or computer language, in any form or by any means, electronic, mechanical, magnetic, optical, chemical, manual or otherwise, without the prior written permission of Embedded Artists AB.

### **Disclaimer**

Embedded Artists AB makes no representation or warranties with respect to the contents hereof and specifically disclaim any implied warranties or merchantability or fitness for any particular purpose. Information in this publication is subject to change without notice and does not represent a commitment on the part of Embedded Artists AB.

### **Feedback**

We appreciate any feedback you may have for improvements on this document. Please send your comments to [support@EmbeddedArtists.com](mailto:support@EmbeddedArtists.com).

### **Trademarks**

All brand and product names mentioned herein are trademarks, services marks, registered trademarks, or registered service marks of their respective owners and should be treated as such.

# Table of Contents

<b>1</b>	<b>Document Revision History</b>	<b>4</b>
<b>2</b>	<b>Introduction</b>	<b>5</b>
2.1	Contents	5
2.2	Features	5
2.3	ESD Precaution	6
2.4	General Handling Care	6
2.5	Other Products from Embedded Artists	6
2.5.1	Design and Production Services	6
2.5.2	OEM / Education / QuickStart Boards and Kits	6
<b>3</b>	<b>Board Design</b>	<b>7</b>
3.1	Board Schematics	7
3.1.1	Page 2: Connectors	7
3.1.2	Page 2: 128x128 Color LCD	7
3.1.3	Page 2: I/O-expansion via I2C	7
3.1.4	Page 2: Joystick	7
3.1.5	Page 2: 3-axis accelerometer	7
3.1.6	Page 2: uSD/transflash memory card interface	7
3.1.7	Page 2: Full-modem RS232	7
3.1.8	Page 3: 10Mbps Ethernet interface	8
3.1.9	Page 3: GPS interface	8
3.2	I/O-pin Usage Summary	8
3.3	Jumpers	10
3.4	Connectors	11
3.5	Important Components	12
3.6	Mechanical Dimensions	13
3.7	Connect to LPC2103/LPC2138/LPC2148 Education Boards	14

# 1 Document Revision History

<i>Revision</i>	<i>Date</i>	<i>Description</i>
A	2009-07-28	First version
B	2012-01-13	Removed schematic from document.

## 2 Introduction

Thank you for buying Embedded Artists' *Experiment Expansion Board*, designed for the *LPC2103/LPC2138/LPC2148 Education Boards*. This document is a User's Guide that describes the *Experiment Expansion Board* hardware design.

### 2.1 Contents

The box received when ordering the *Experiment Expansion Board* contains:

- The *Experiment Expansion Board*

Note that one 20 pos or 50 pos flat cable is also needed to connect the *Experiment Expansion Board* to a *LPC2103/LPC2138/LPC2148 Education Board*. This flat cable is included in the *LPC2103/LPC2138/LPC2148 Education Board* kits.

### 2.2 Features

Embedded Artists *Experiment Expansion Board* lets you continue experimenting with the *LPC2103/LPC2138/LPC2148 Education Boards*. Here are the features of the board:

- On-board Peripherals
  - 128x128 color LCD (interface via SPI bus) with backlight control
  - 3-axis accelerometer (MMA7260 from Freescale)
  - 10M Ethernet interface (ENC28J60 from Microchip, interface via SPI bus)
  - Joystick switch
  - 2 push buttons
  - 16 LEDs controlled via I2C (PCA9532)
  - uSD/transflash connector (interface via SPI bus)
  - Full-signal RS232 modem
  - Interface to GPS module (A1035-C from Tyco Electronics).  
*Note that GPS module is not included.*
- Connectors
  - 9-pos male DSUB (RS232 interface)
  - RJ45 connector (Ethernet interface)
  - uSD/transflash memory card connector
  - interface to GPS module
  - 20 pin input expansion connector (to *LPC2103 Education Board*)
  - 50 pin input expansion connector (to *LPC2138 Education Board* and *LPC2148 Education Board*)
- Power
  - Powered with +3.3V from expansion connectors (either 20- or 50-pos connector). Needs at least 200 mA.
- Dimensions: 122 x 78 mm

- Four layer PCB (FR-4 material) for best noise immunity

### 2.3 ESD Precaution

Please note that the *Experiment Expansion Board* come without any case/box and all components are exposed for finger touches – and therefore extra attention must be paid to ESD (Electro-Static Discharge) precaution.

***Make it a habit always to touch the metal surface of the uSD/transflash connector for a second with both hands before touching any other parts of the boards.*** That way, you will have the same electrical potential as the board and therefore minimize the risk for ESD.



***Note that Embedded Artists does not replace boards that have been damaged by ESD.***

### 2.4 General Handling Care

Handle the *Experiment Expansion Board* with care. The board is not mounted in a protective case/box and is not designed for rough physical handling. Connectors can wear out after excessive use. The board is designed for evaluation and prototyping use, and not for integration into consumer or industrial end-products.

The *Experiment Expansion* has an LCD. Do not exercise pressure on the display glass area or the flex cable connecting the display to the pcb. That will damage the display.

***Note that Embedded Artists does not replace boards where the LCD has been improperly handled.***

### 2.5 Other Products from Embedded Artists

Embedded Artists have a broad range of LPC1000/2000/3000/4000 based boards that are very low cost and developed for prototyping / development as well as for OEM applications. Modifications for OEM applications can be done easily, even for modest production volumes. Contact Embedded Artists for further information about design and production services.

#### 2.5.1 Design and Production Services

Embedded Artists provide design services for custom designs, either completely new or modification to existing boards. Specific peripherals and I/O can be added easily to different designs, for example, communication interfaces, specific analog or digital I/O, and power supplies. Embedded Artists has a broad, and long, experience in designing industrial electronics in general and with NXP's LPC1000/2000/3000/4000 microcontroller families in specific. Our competence also includes wireless and wired communication for embedded systems. For example IEEE802.11b/g (WLAN), Bluetooth™, ZigBee™, ISM RF, Ethernet, CAN, RS485, and Fieldbuses.

#### 2.5.2 OEM / Education / QuickStart Boards and Kits

Visit Embedded Artists' home page, [www.EmbeddedArtists.com](http://www.EmbeddedArtists.com), for information about other *OEM / Education / QuickStart* boards / kits or contact your local distributor.

## 3 Board Design

This chapter contains detailed information about the electrical and mechanical design of the *Experiment Expansion Board*. The schematic can be downloaded in pdf format from the support page, and is recommended to have printed out while reading this chapter.

### 3.1 Board Schematics

The following subsections describe in more detail each part of the design, page by page in the schematic.

#### 3.1.1 Page 2: Connectors

There is one 20-pos and one 50-pos connector to interface the board. The 20-pos connector is used for the *LPC2103 Education Board*. The 50-pos connector is used for the *LPC2138/LPC2148 Education Boards*. A flat cable is typically used to connect the *Experiment Expansion Board* with any of the *LPC2103/LPC2138/LPC2148 Education Boards*.

#### 3.1.2 Page 2: 128x128 Color LCD

There is a 128x128 pixel color LCD that is connected to the SPI-bus. P0.7 is used for SSEL (chip select). There is a backlight LED on the display, which is controlled by a constant current LED driver (LT1932). Signal P0.15 is used to control the driver. A high signal turns the driver on. The signal can be constantly driven (high or low) but it is also possible to connect a PWM signal (typically 1-10kHz). By varying the duty signal of the signal, the backlight intensity can be controlled.

#### 3.1.3 Page 2: I/O-expansion via I2C

There is an i/o-expansion chip (PCA9532) connected to the i2c-bus. 16 LEDs are connected to the i/o-pins as well as two push-buttons.

#### 3.1.4 Page 2: Joystick

There is a joystick that has 5 keys; up/down/left/right/center that are connected directly to i/o-pins P0.8 – P0.12.

#### 3.1.5 Page 2: 3-axis accelerometer

There is a 3-axis accelerometer (MMA7260QT from Freescale) that generates analog voltages corresponding to the accelerometer in each direction. The output signals are connected to signal P0.21, P0.22, P0.30 on the 50-pos connector and P0.23, P0.24, P0.25 on the 20-pos connector. These signals can be analog inputs on the *Education Boards*.

Pin P0.13 and P0.14 controls the sensitivity (gain) of the accelerometer. See datasheet for details.

#### 3.1.6 Page 2: uSD/transflash memory card interface

There is a uSD/transflash memory card connector that is connected to the spi-bus. P0.13 is used for SSEL (select). P0.16 is a 'card detect' signal. It is low when a card is inserted in the connector. This signal is not strictly needed and can be ignored. An inserted card can be detected by trying to communicate with the card over the spi-bus.

There are no jumpers to connect/disconnect the uSD/transflash connector. If the interface is not used, just do not insert any memory card in the connector. In that case no signals are affected (other than 10K ohm pull-up resistors on P0.5 and P0.16).

#### 3.1.7 Page 2: Full-modem RS232

There is a RS232 interface with all modem signals connected. The interface connects to UART#1 on the *Education boards*. There are jumpers to (just) connect the signals that are needed, i.e., it is not necessary to connect all modem signals.

### 3.1.8 Page 3: 10Mbps Ethernet interface

There is a 10Mbps Ethernet interface implemented around the ENC28J60 from Microchip. The chip has spi interface. P0.14 is used for SSEL (chip select). There is an optional interrupt signal connected to P0.15. All signals to the ENC28J60 can be connected/disconnected via six jumpers.

### 3.1.9 Page 3: GPS interface

There is a connector (dual row pin list, 2x11 pos) for the A1035-C GPS module from Tyco Electronics. The module interface is a simple asynchronous serial channel; 4800 bps, 8N1. The serial interface of the GPS module is always connected to P0.8 and P0.9 (via 270 ohm resistors). In this case the *Education Boards* can communicate with the GPS module over UART#1. It is also possible to connect the serial channel of the GPS module to the RS232 interface. A PC can then communicate with the GPS module over a COM-port. In this case, the *Education Boards* cannot communicate with the GPS module. The *Experiment Expansion Board* is just used to create a RS232 interface to the GPS module.

If the GPS interface is not used, just do not insert any GPS module in the interface connector. No signals are affected if no GPS module is inserted.

## 3.2 I/O-pin Usage Summary

The table below summarizes the I/O-pin usage for the different on-board peripheral functions on the *Experiment Expansion Board*.

50-pos connector	20-pos connector	128x128 LCD	IO-expansion	Joystick	Accelerometer	uSD	RS232	Ethernet	GPS
P0.0									
P0.1									
P0.2	P0.2		I2C-SCL						
P0.3	P0.3		I2C-SDA						
P0.4	P0.4	SPI-SCK				SPI-SCK		SPI-SCK	
P0.5	P0.5					SPI-MISO		SPI-MISO	
P0.6	P0.6	SPI-MOSI				SPI-MOSI		SPI-MOSI	
P0.7	P0.7	SPI-SSEL							
P0.8	P0.8			X			X		X
P0.9	P0.9			X			X		X
P0.10	P0.10			X			X		
P0.11	P0.11			X			X		
P0.12	P0.12			X			X		
P0.13	P0.13				X	SPI-SSEL	X		
P0.14	P0.14				X		X	SPI-SSEL	
P0.15	P0.15	Backlight control					X	Interrupt	
P0.16						X			
P0.17									
P0.18									
P0.19									
P0.20									
P0.21						X (50-pos)			

P0.22					X (50-pos)				
P0.23	P0.23				X (20-pos)				
	P0.24				X (20-pos)				
P0.25	P0.25				X (20-pos)				
P0.26									
P0.27									
P0.28									
P0.29									
P0.30					X (50-pos)				
P0.31									
Reset	Reset	Reset	Reset					Reset	
<b>50-pos connector</b>	<b>20-pos connector</b>	<b>128x128 LCD</b>	<b>IO-expansion</b>	<b>Joystick</b>	<b>Accelerometer</b>	<b>uSD</b>	<b>RS232</b>	<b>Ethernet</b>	<b>GPS</b>

Note that some pins are connected to several different on-board peripherals. Some peripherals cannot be used simultaneously:

- Accelerometer and uSD/transflash interface, because one of the sensitivity select signals for the accelerometer is also used for spi-select.
- Accelerometer and Ethernet, because one of the sensitivity select signals for the accelerometer is also used for spi-select.
- RS232/GPS and Joystick, because P0.8-P0.12 can either be general purpose i/o-pins or UART pins.
- RS232 (connected to an *Education Board*) and GPS, because both use the same UART on an *Education Board*.
- RS232 and Ethernet, because P0.14-P0.15 are shared. Note that if P0.14-P0.15 are not used for the RS232 interface, then RS232 and Ethernet can be active simultaneously.
- Backlight control of LCD and interrupt signal of Ethernet use the same pin (P0.15). It is possible to implement the Ethernet driver without interrupts (i.e., polling is used instead). In that case, P0.15 can be used to control the LCD backlight and Ethernet can still be active.

### 3.3 Jumpers

The *Experiment Expansion Board* has got a number of jumpers. *Figure 1* illustrates where the jumpers can be found. The picture below also illustrates the default positions for all jumpers.

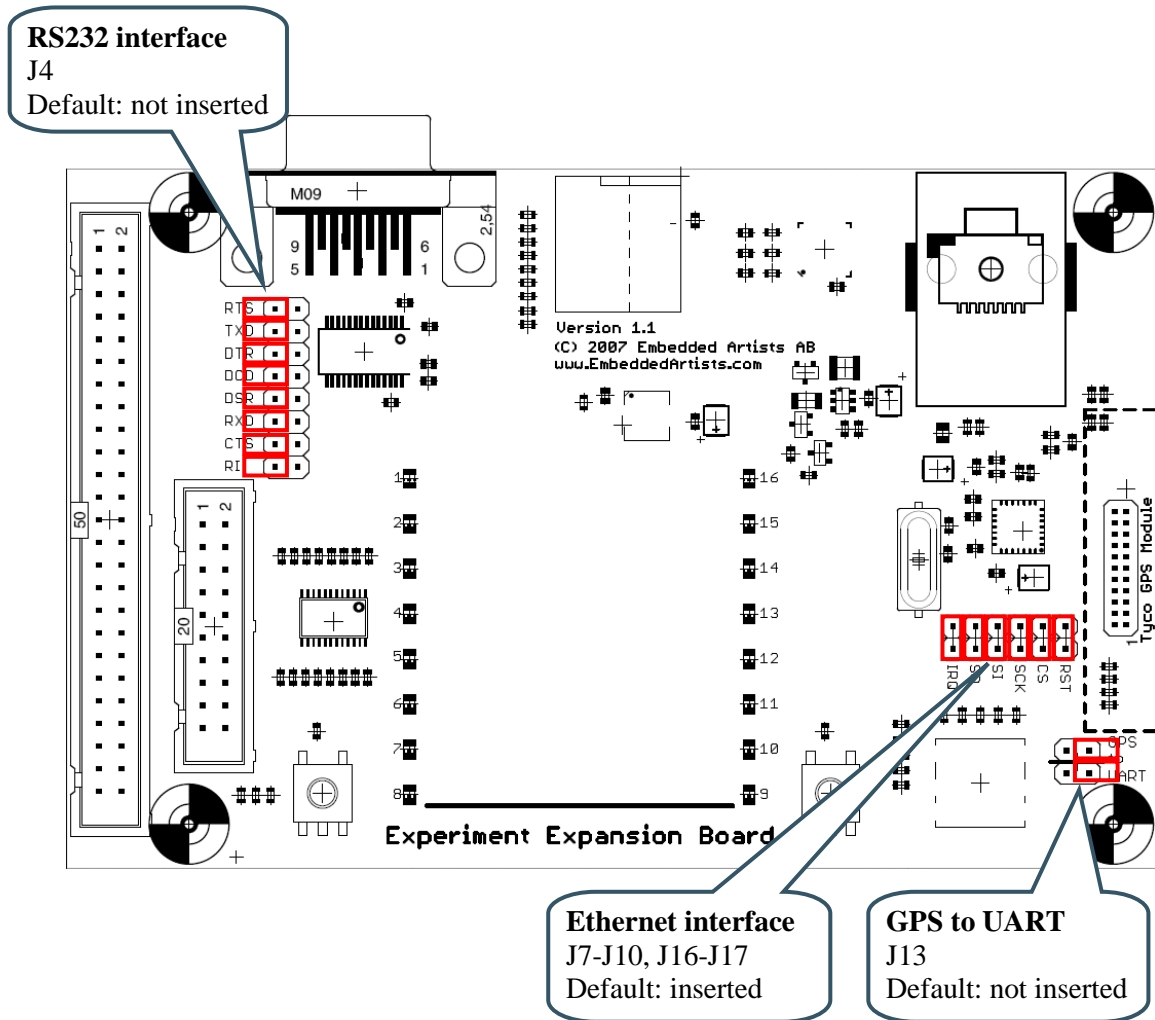

Figure 1 – Experiment Expansion Board Jumpers

### 3.4 Connectors

Figure 2 illustrates the position of the two external connectors on the *Experiment Expansion Board*.

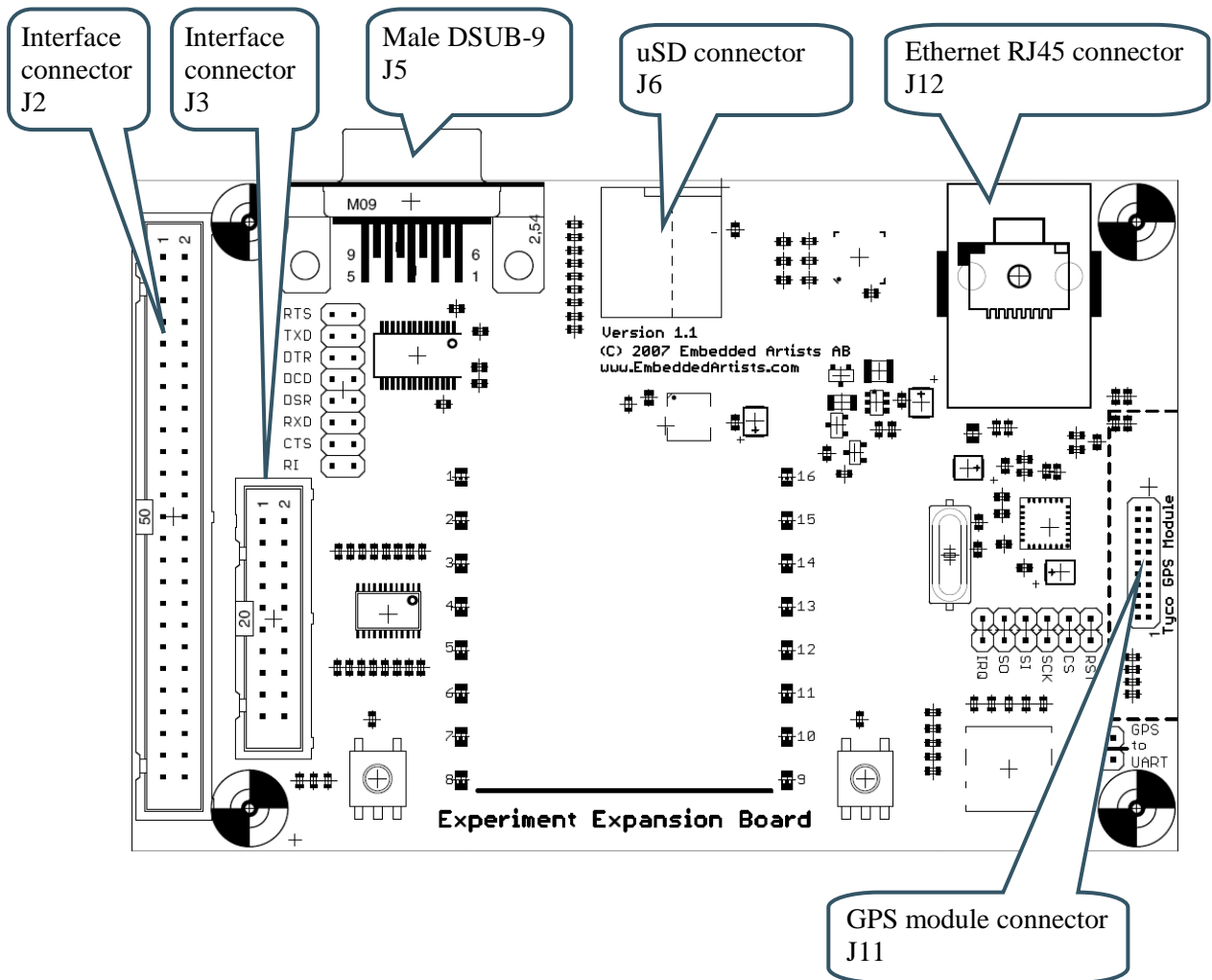

Figure 2 - Experiment Expansion Board External Connectors

### 3.5 Important Components

Figure 3 illustrates the position on the board for some important components in the design.

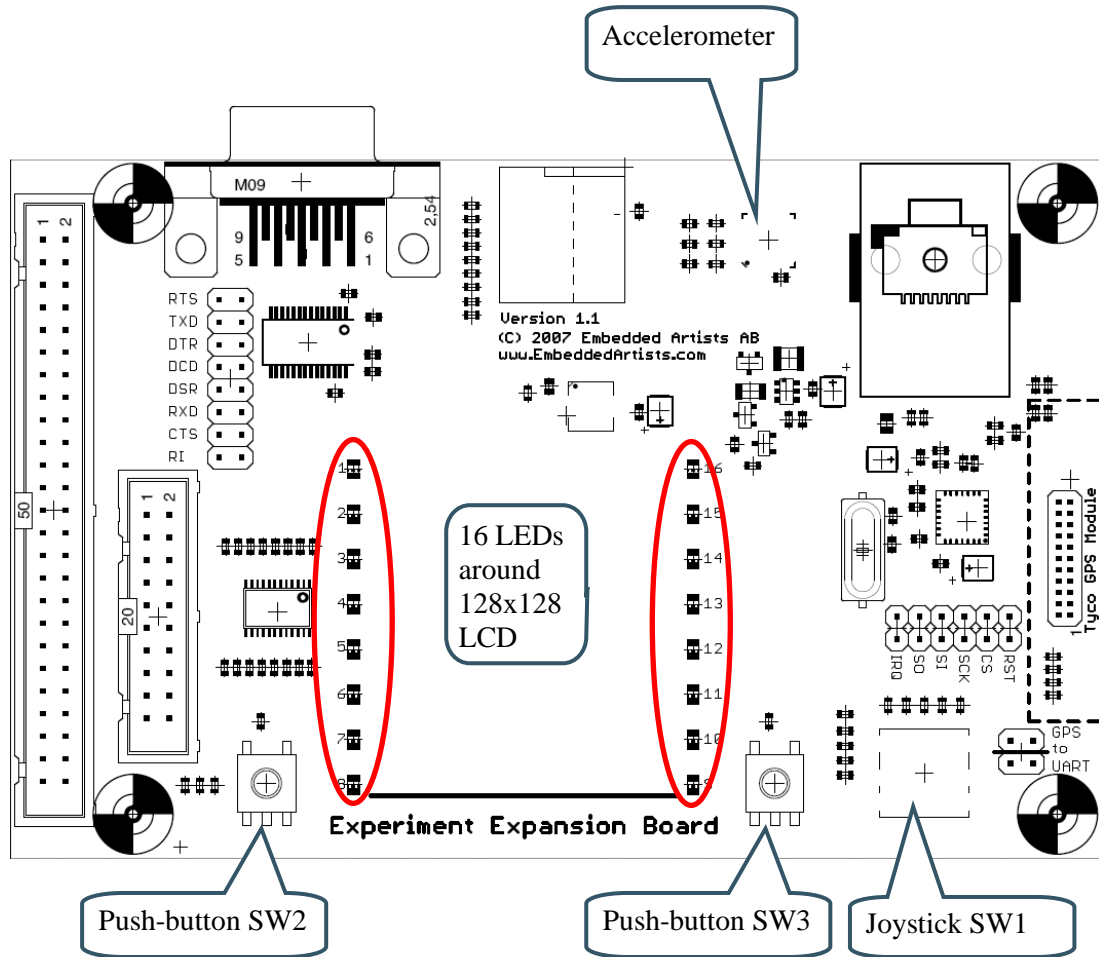

Figure 3 - Experiment Expansion Board Important Components

### 3.6 Mechanical Dimensions

Figure 4 contains a drawing of the board that includes mechanical measures.

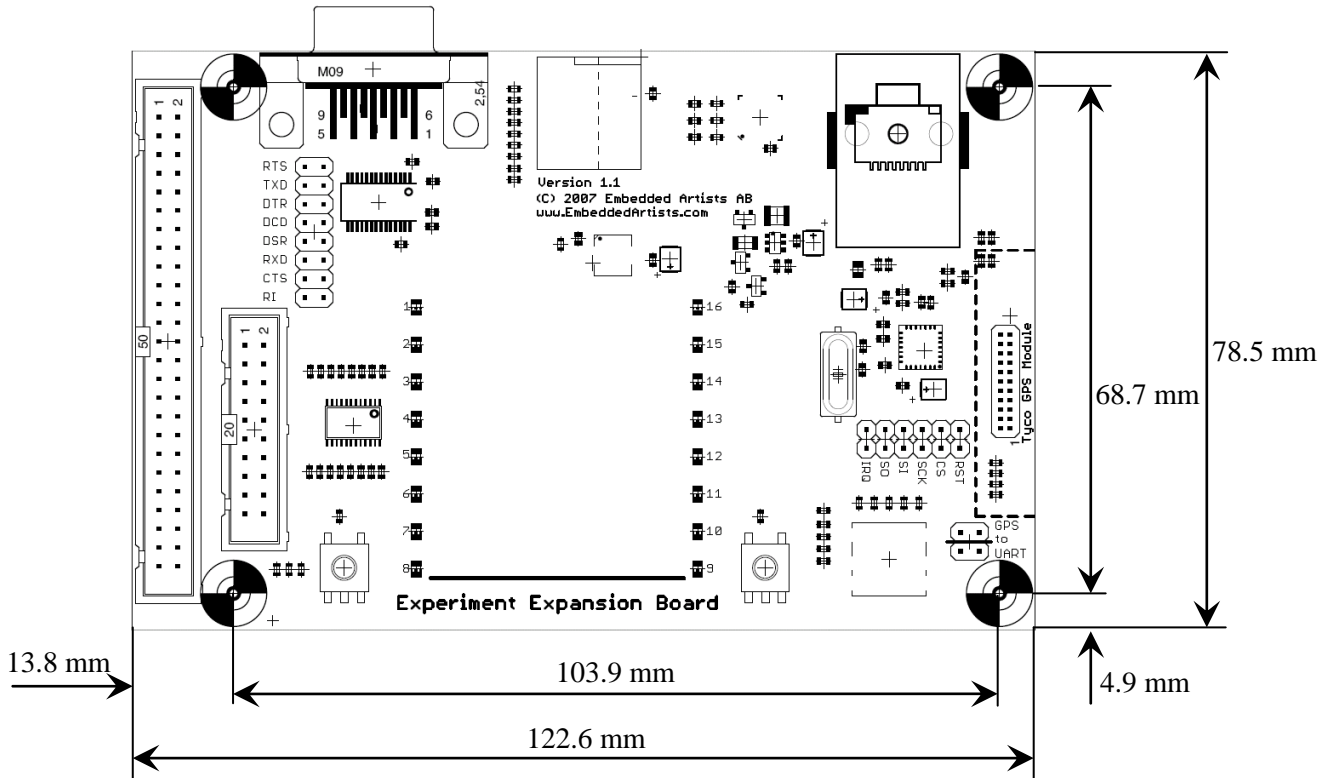

Figure 4 - Experiment Expansion Board Mechanical Dimensions

### 3.7 Connect to LPC2103/LPC2138/LPC2148 Education Boards

The pictures below illustrate how the *Experiment Expansion Board* is connected via either a 20-pos or a 50-pos flat cable to the *LPC2103/LPC2137/LPC2148 Education Boards*.

Note that the flat cables come with the *Education Boards* and not with the *Experiment Expansion Board*.



Figure 5 - LPC2103 Education Board with Experiment Expansion Board

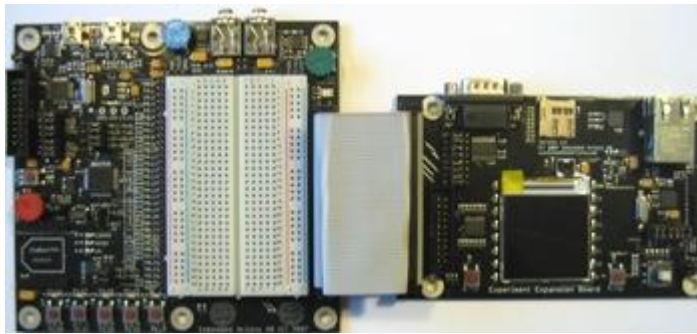

Figure 6 - LPC2138 Education Board with Experiment Expansion Board



Figure 7 - LPC2148 Education Board with Experiment Expansion Board